

HAMBURGER'S

SUPERCHARGERS

TM

**2015-2019 Dodge Ram 5.7L HEMI
Supercharger System
Installation Manual**

Important Notes:

- If you have any questions or concerns with this kit please call: 732-240-3696
- The use of **MINIMUM** 91 Octane E10 Fuel is mandatory. 93 Octane E10 is **HIGHLY RECOMMENDED**
- The use of fuel additives is not recommended. There is a possibility that these chemicals can damage your engine and cause drivability issues with your vehicle.

BEFORE BEGINNING INSTALLATION SEND THE ECM BACK TO HAMBURGERS SUPERCHARGERS USING THE INCLUDED SHIPPING LABEL AND BOX. THIS WILL ALLOW TIME FOR HAMBURGERS SUPERCHARGERS TO GET THE ECM BACK TO YOU ASAP.

NOTE: IF YOU PURCHASED A “TUNER KIT” THERE IS NO NEED TO REMOVE THE ECU.

WARNING: Hamburgers Superchargers Inc. recommends allowing the vehicle to cool (not running) for two hours before beginning installation.

WARNING: To avoid the chance of electrical shock or damage to your vehicle’s electrical system, disconnect both the negative and positive battery leads (in that order) at the battery.

FUEL SYSTEM PRESSURE RELEASE

WARNING:

The fuel system is under constant high pressure even with engine off. Until the fuel pressure has been properly released from the system, do not attempt to open the fuel system. Do not smoke or use open flames/sparks when servicing the fuel system. Wear protective clothing and eye protection. Make sure the area in which the vehicle is being serviced is in a well ventilated area and free of flames/sparks. Failure to comply may result in serious or fatal injury.

FUEL SYSTEM PRESSURE RELEASE

1. Remove the fuel pump relay from the Power Distribution Center (PDC). The relay location label can be found on the underside of the PDC cover.
2. Start and run the engine until it stalls.
3. Attempt restarting engine until it will no longer run.
4. Turn ignition to the OFF position.
5. Return fuel pump relay to the Power Distribution Center (PDC).

Disassembly

1. To begin, perform the fuel system pressure release as described above. The fuel system will be opened during this installation so it is necessary to release the fuel pressure before removing the ECU.
2. Then the ECU will have to be removed and sent to HSI using the prepaid shipping label and box provided. We will make the necessary changes and send the ECU back same day in most cases to minimize vehicle downtime. The ECU is located on the passenger side of the firewall underneath the cowl as shown below.
3. First remove the factory air intake system in order to gain easier access to the ECU. The factory airbox and air intake tube can be removed as an assembly by following the steps below.
 - a. Disconnect the air intake temperature sensor electrical connector from air intake tube.
 - b. Loosen the worm drive clamp at the throttle body, remove air intake tube from the throttlebody.
 - c. Disconnect the makeup air hose at the airbox.
 - d. Pull the airbox straight up to remove from the rubber mounts.

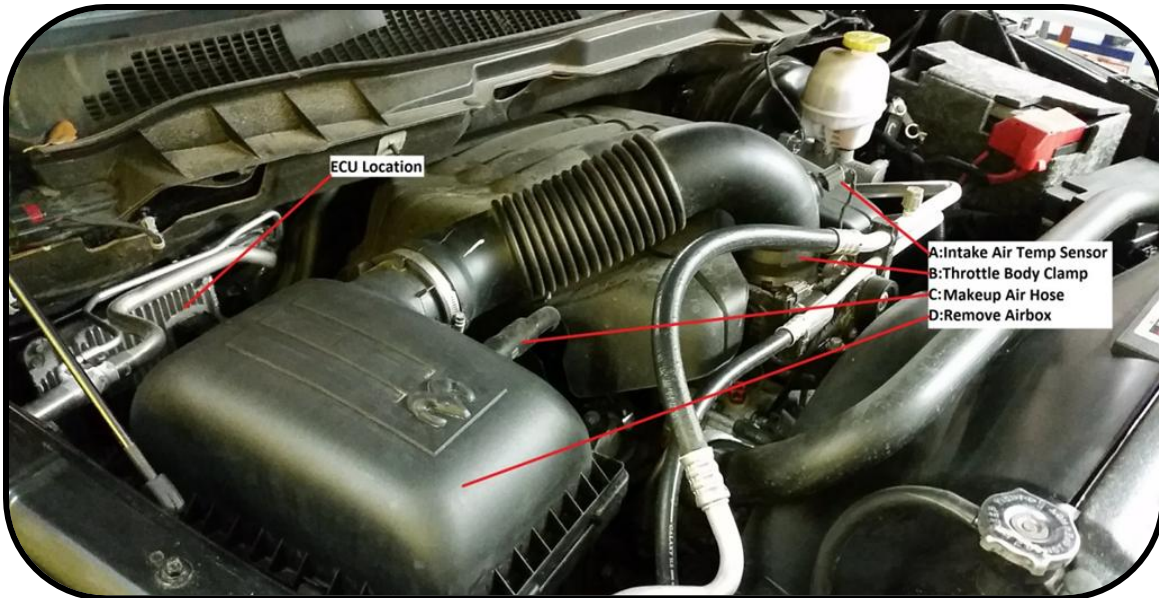

4. Remove the ECU by following the steps below.

- a. Disconnect the ground cable from the vehicles battery.
- b. Disconnect the two ECU Connectors.
 - i. Depress the small black tab.
 - ii. Lift UP on the large red lever.
- c. Remove the ECU mounting hardware.

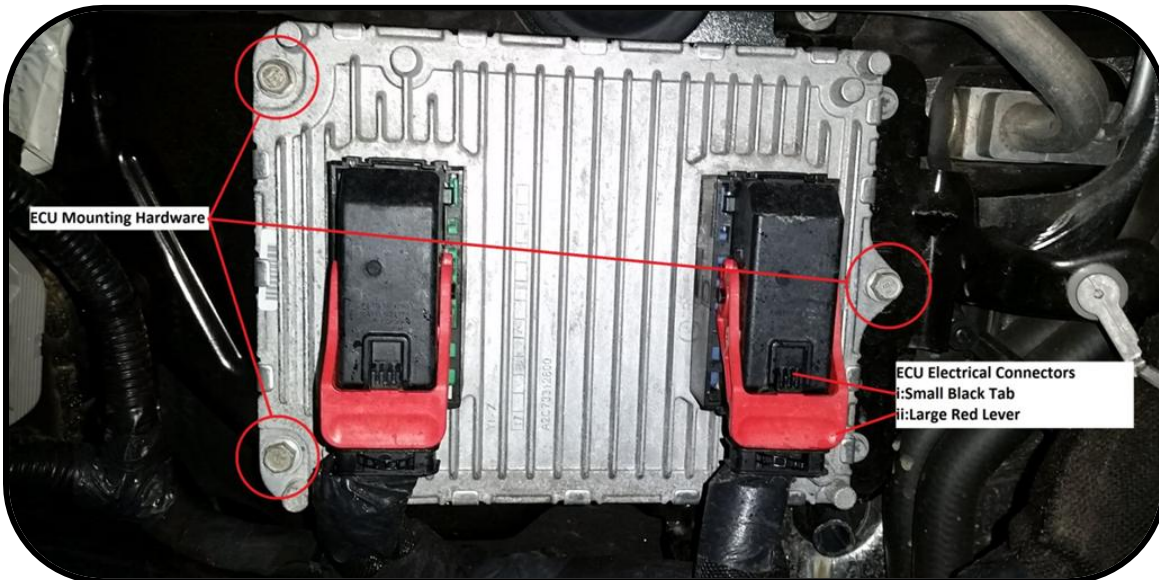

5. Remove the factory engine cover; lift up on the front to release from rubber mounts and pull forward to remove.
6. The factory spark plugs will need to be removed and the colder plugs supplied in this kit will need to be installed in place. Disconnect the coil electrical connector and remove the coil mounting hardware. Remove the coil and replace the spark plugs (two plugs per cylinder). Reinstall the coil pack and mounting hardware when complete. Repeat for all eight cylinders.

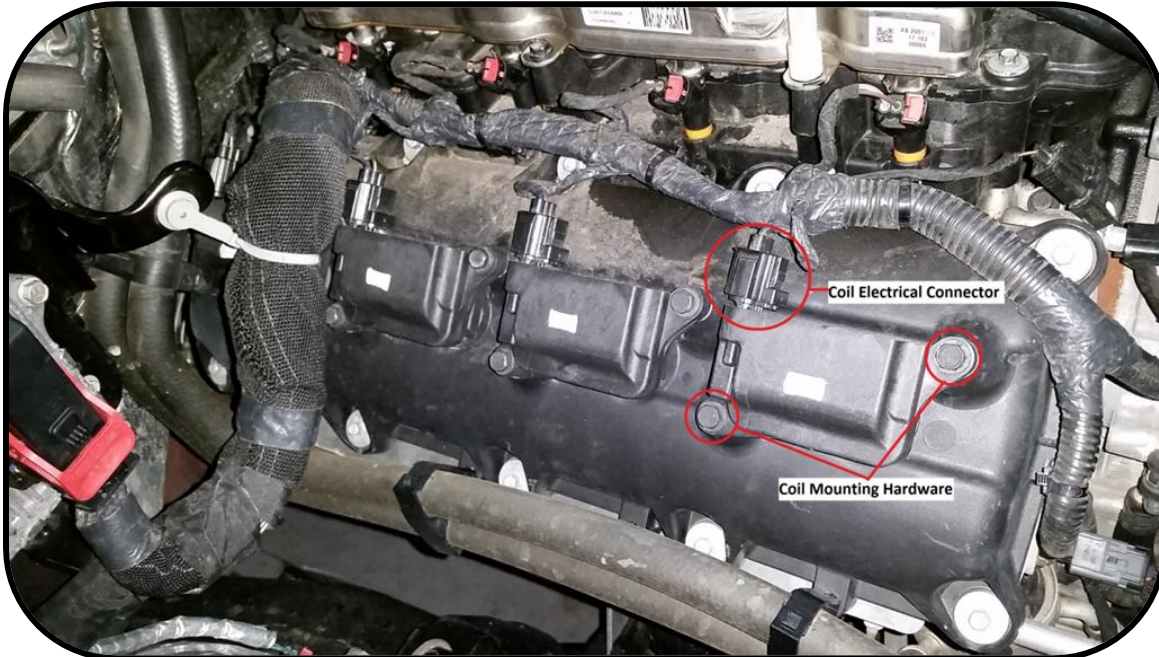

7. The factory intake manifold o-ring gaskets are not capable of supporting boost. Under any amount of pressure the factory o-ring gaskets will fail and allow an atomized fuel and air mixture to leak into the engine compartment at wide open throttle. In order to remedy this, the factory intake must be removed and the factory gaskets will need to be replaced and supported. The steps outlined below describe this process.

- a. Disconnect the following electrical connectors:
 - i. Fuel Injector Connectors (Eight Total)
 - ii. Electronic Throttle Body Connector
 - iii. MAP Sensor Connector
 - iv. SRV Connector (If Equipped – Located on Back of Intake Manifold)

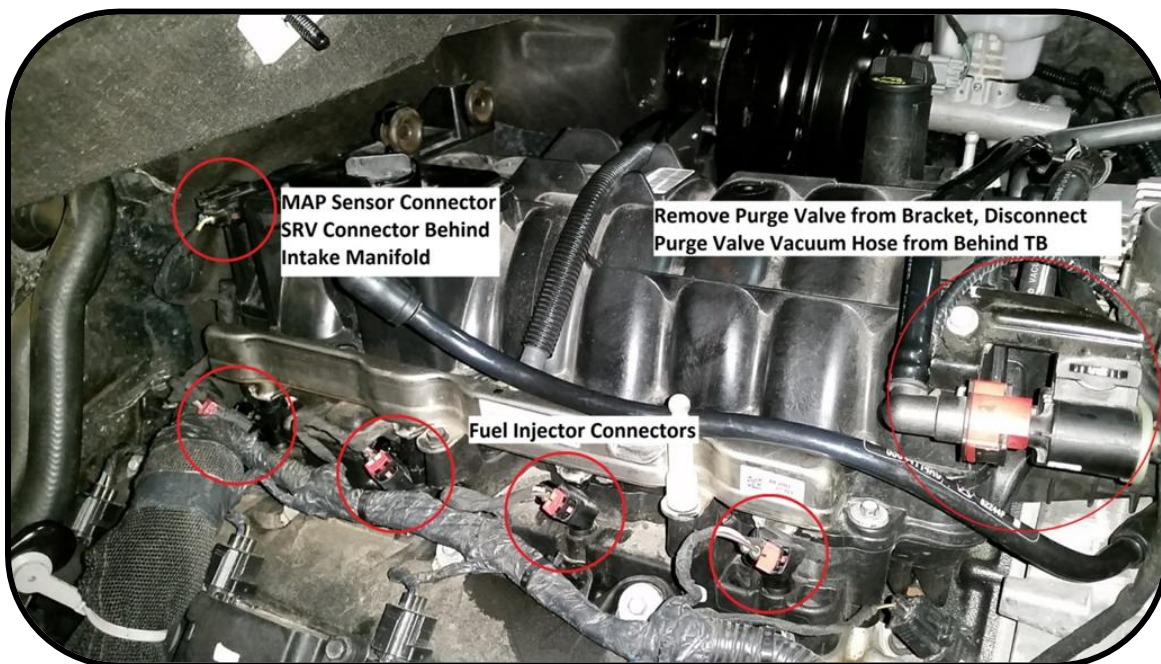

- b. Disconnect the fuel feed line at the fuel rail.
- c. Disconnect the purge valve vacuum hose at the front of the intake manifold behind the throttle body; remove the purge valve from the bracket on the passenger side of the intake manifold.

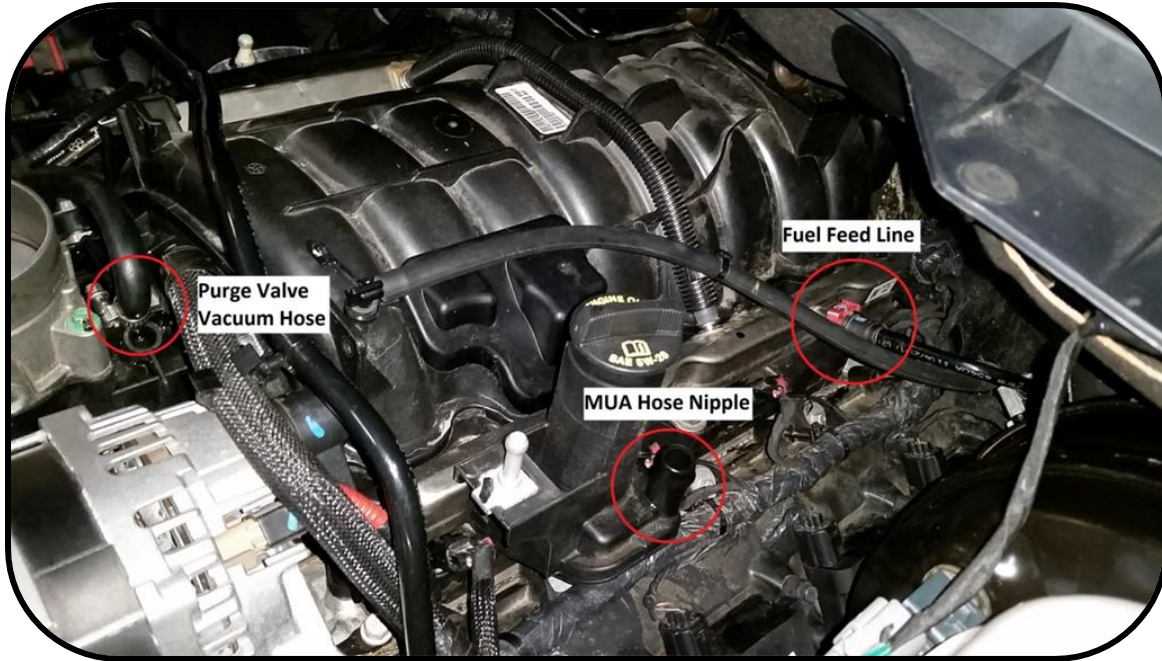

- d. Locate the hose that runs between the back of the intake manifold and the brake booster. On the brake booster side disconnect the electrical connector and remove the barbed end from the brake booster. This hose will come out with the intake.



- e. At this point you can remove the intake manifold hardware shown below and then remove the intake manifold. Follow the sequence shown when removing or installing the intake manifold hardware.



8. Once the intake manifold is removed, remove the old o-ring gaskets and discard. Clean any oil or debris out of the o-ring channel and install the new provided o-ring gaskets.
9. Once the gaskets are installed, you should be able to insert the o-ring supports in between the gasket and the outer edge of the intake manifold as shown below. If installed correctly the new gaskets will be tighter to push in the channel than originally designed and will keep the o-ring support from falling into the cylinder heads when reinstalling the intake manifold. Note: When installing the supports it may be necessary to slightly lift the affected side of the o-ring out of the channel in order for the gasket and support to be able to be installed at the same time.

NOTE: DO NOT LET THE O-RING SUPPORTS FALL INTO THE CYLINDER HEAD. IF THIS OCCURS USE A MAGNET TO REMOVE THE SUPPORT. FAILURE TO REMOVE SUPPORTS FROM THE CYLINDER HEAD WILL CAUSE PERMANENT ENGINE DAMAGE.

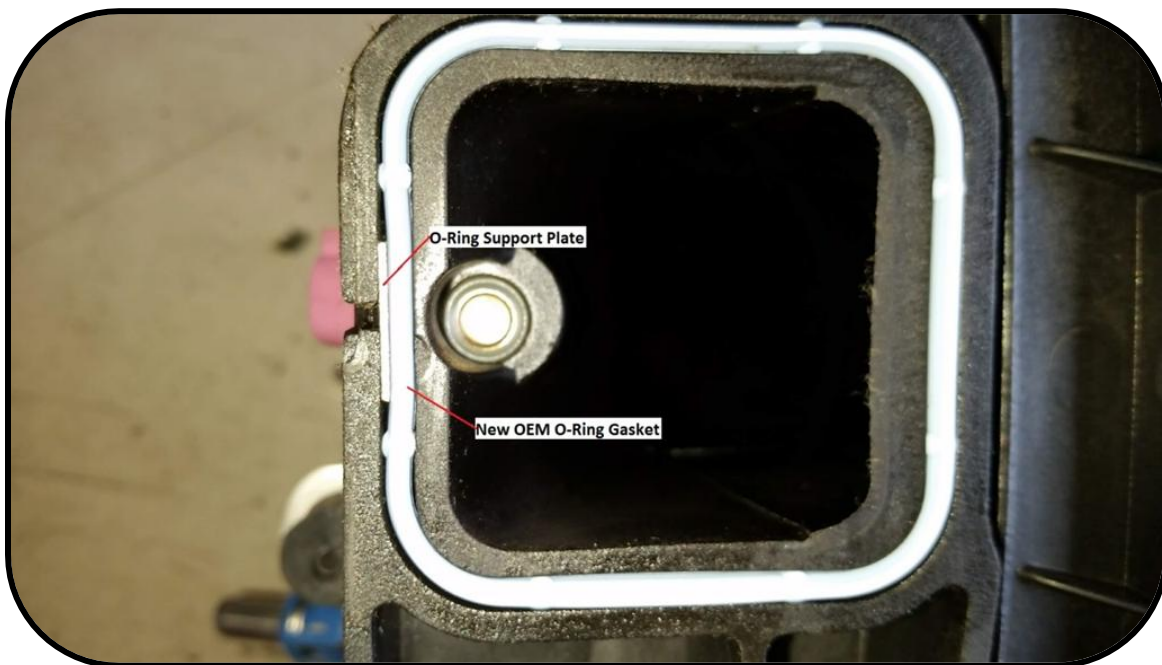

10. Before reinstalling the intake manifold it is a good time to replace the factory fuel injectors with the new higher flow fuel injectors that are supplied with the kit. See below.

- a. Remove the fuel rail from the intake manifold and drain any remaining fuel.
- b. Remove the metal fuel injector clips (2) and remove the injectors (3) from the rail (1).
- c. Install the metal fuel injector clips (2) onto the new injectors (3) and install the assembly into the rail (1).
- d. Reinstall the fuel rail onto the intake manifold.

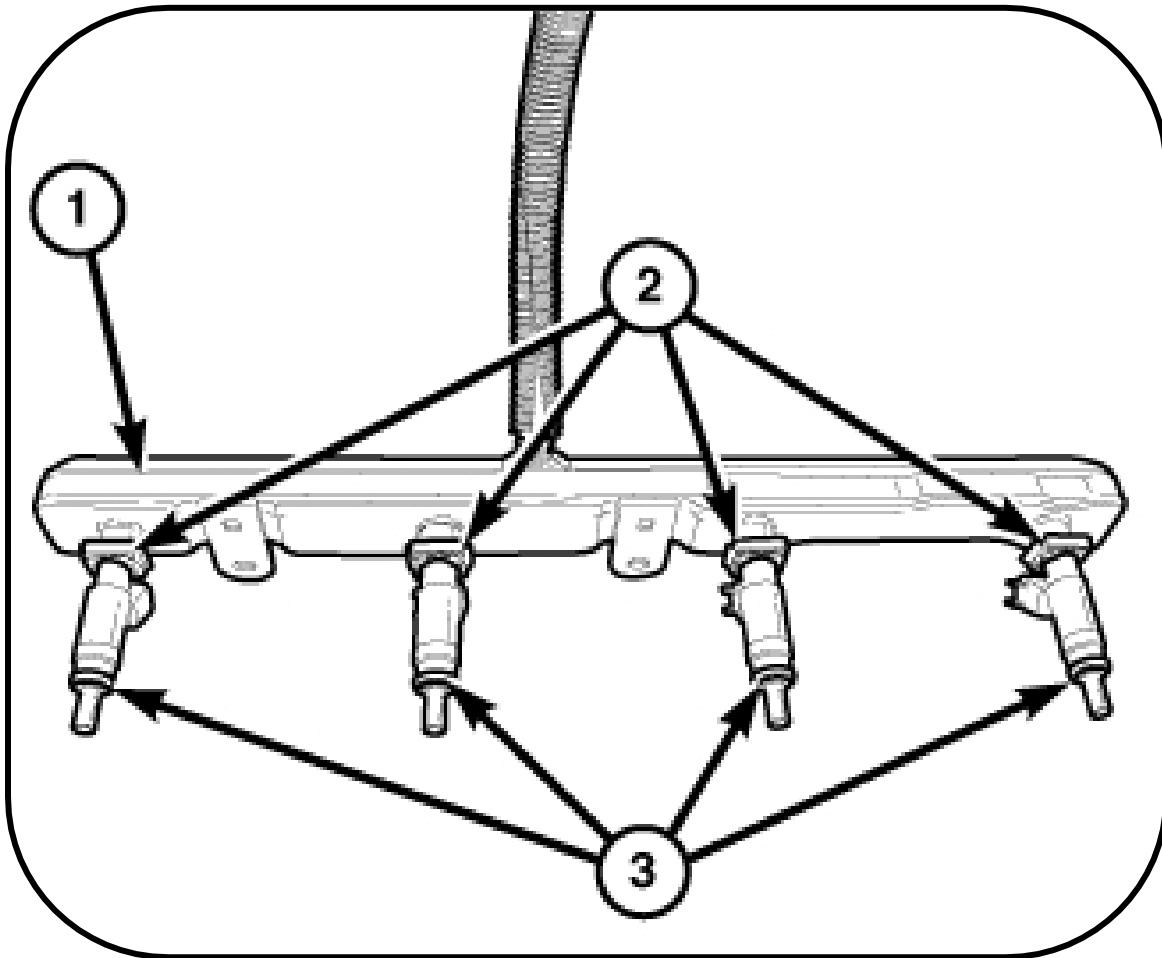

11. The last step before reinstalling the intake manifold is to replace the factory MAP sensor with the new three bar MAP sensor provided with this kit. Rotate sensor 1/4 turn counter-clockwise for removal. To install the new MAP sensor, first you will need to cut off the tab on the side of the new MAP sensor, as well as grind off the alignment tab so the factory connector fits the new MAP sensor. Install the new 3 bar MAP sensor into the intake manifold now.

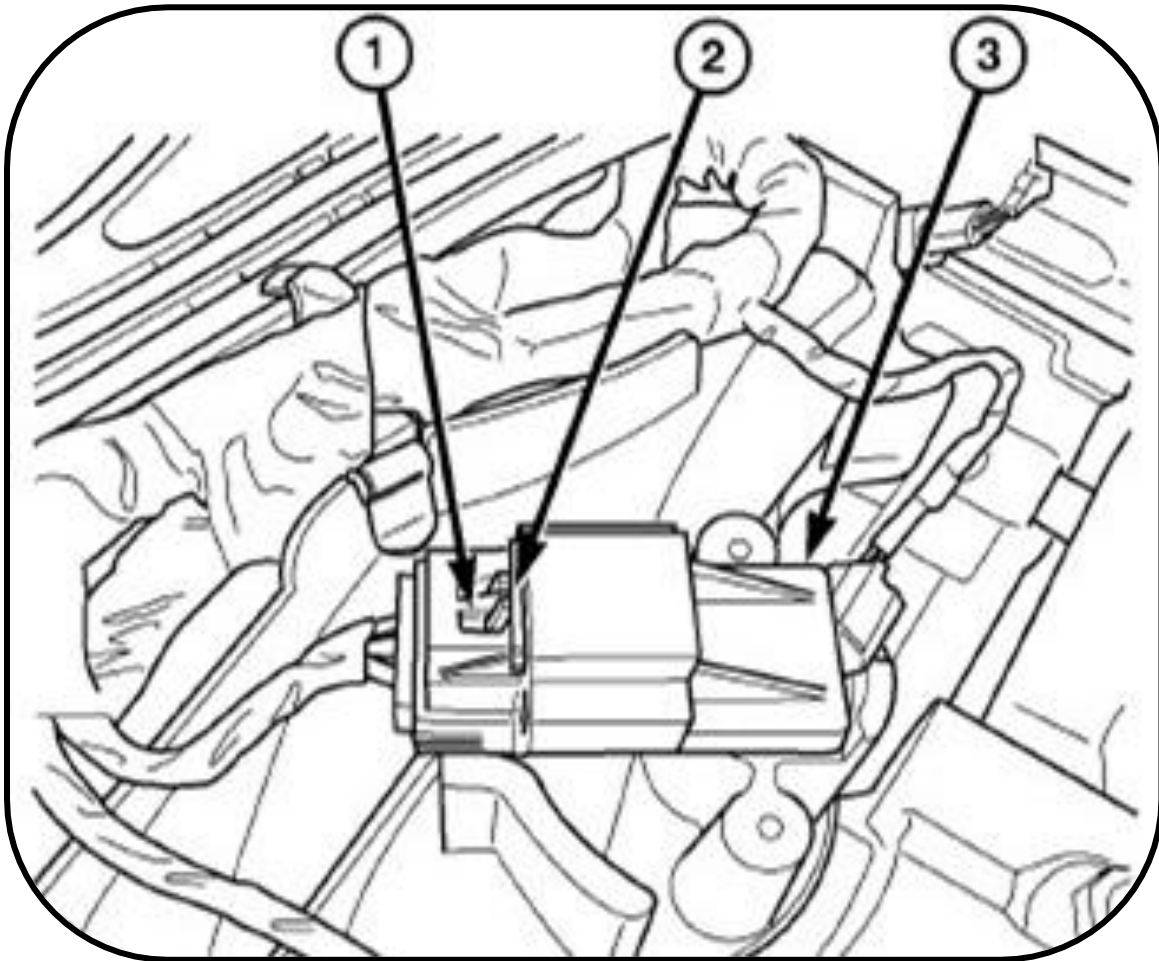

12. Reinstall the intake manifold at this point by reversing the procedure in Step 7 above. Torque the intake manifold hardware to 9 lb-ft following the same sequence shown above. Once the intake manifold is reinstalled all of the supporting modifications are complete and the kit can be installed. **NOTE: RETORQUE INTAKE MANIFOLD TO 9 LB-FT AFTER COMPLETION OF INSTALLATION. RECHECK TORQUE AFTER 3-4 HEAT CYCLES HAVE BEEN COMPLETED. NOTE: DEPENDING ON THE YEAR OF YOUR RAM YOU MAY HAVE TO USE THE FACTORY INTAKE BOLTS RATHER THEN THE SUPPLIED HARDWARE.**

13. Once the intake manifold is reinstalled all of the supporting modifications are complete and the kit can be installed. Start by removing the six x-mas tree pins shown below to remove the radiator sight shield.

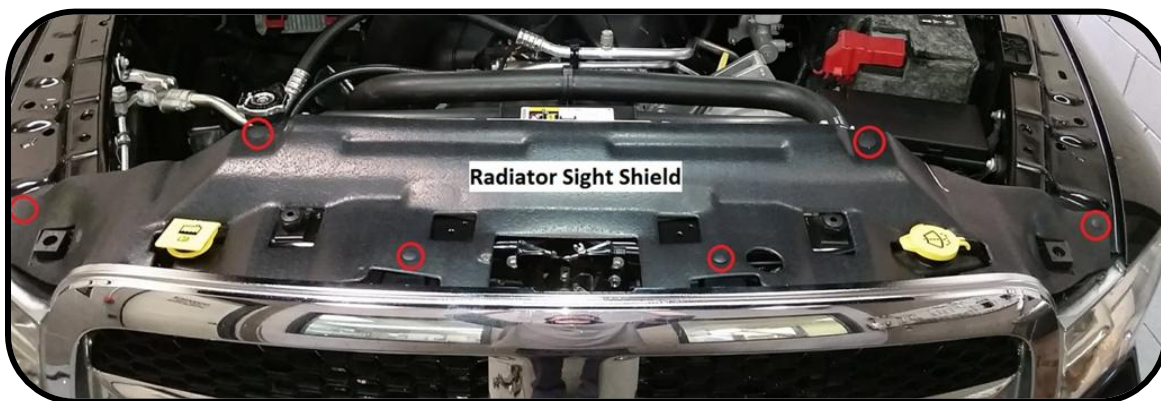

14. Remove the four 10MM bolts/screws securing the top of the grill. Pull the bottom of the grill out from the front of the vehicle to release the pop clips and remove the grill.



15. Remove the shutter hardware indicated below. When removing the shutters don't forget to disconnect the electrical connector. The shutters will not be reinstalled.

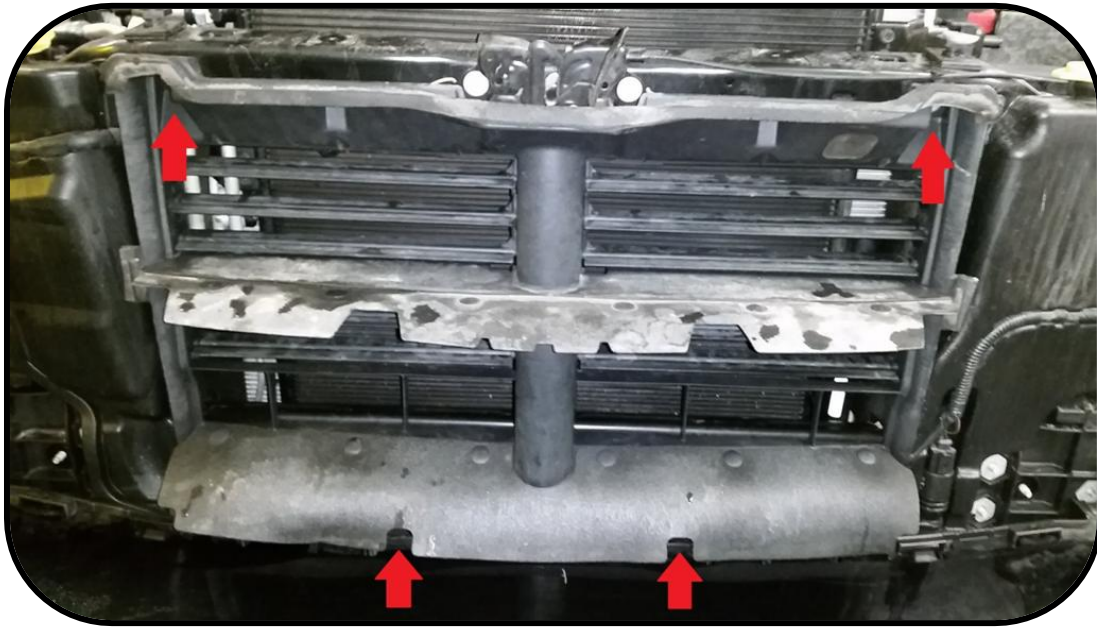

16. Remove the lower splash shield. The splash shield will not be reinstalled.



17. Remove the lower radiator fan shroud by releasing the locking tabs on the bottom, then swing the bottom towards the engine and drop the shroud straight down.

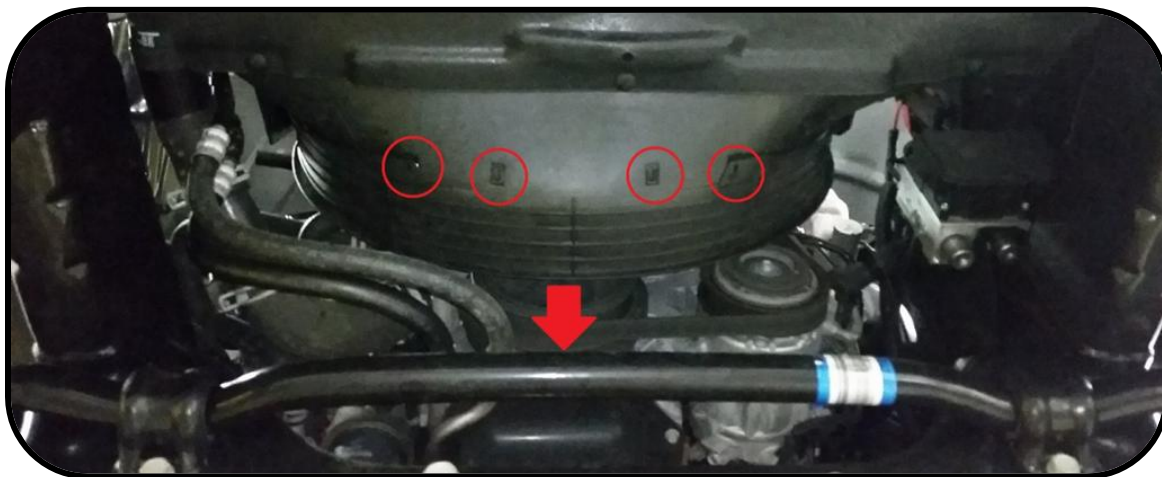

18. Remove the upper radiator fan shroud and electric fan together by following the steps below.

a. Disconnect the electrical connector for the fan.

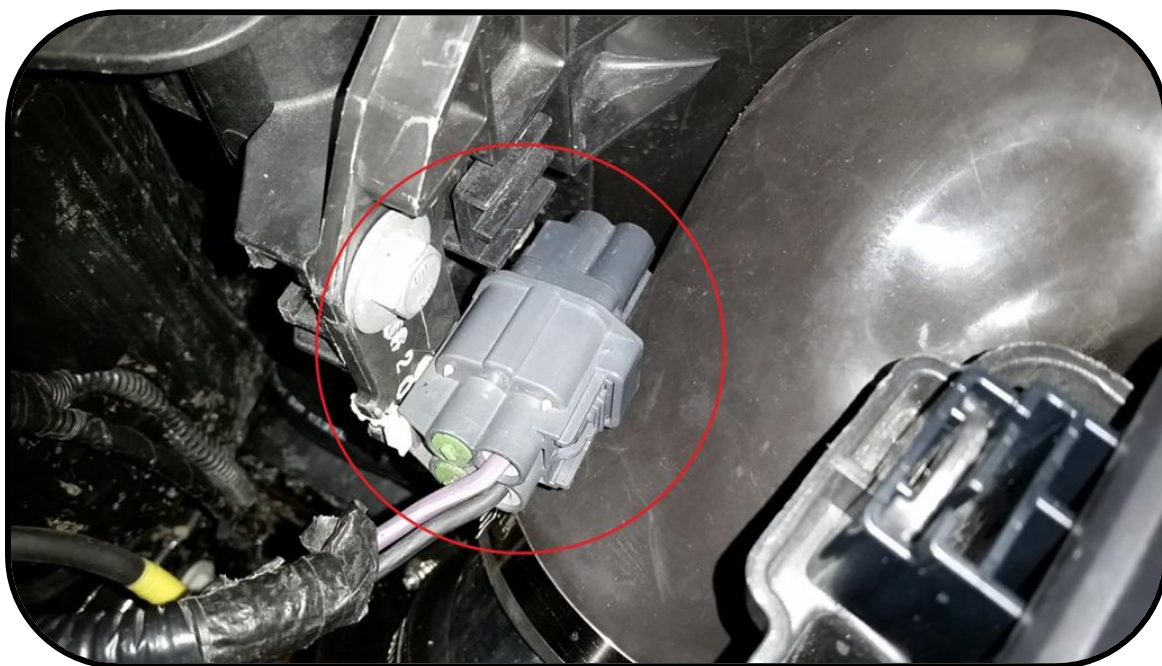

b. Remove the radiator hose mount from the upper fan shroud.



c. Remove the two metal locking tabs securing the electric fan to the radiator.

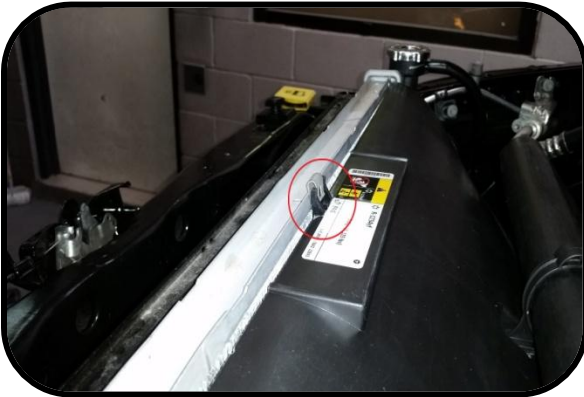

d. Remove the two 13MM bolts securing the fan shroud to the radiator support.

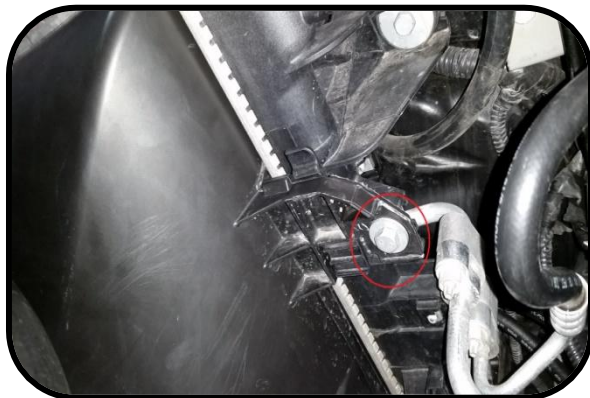
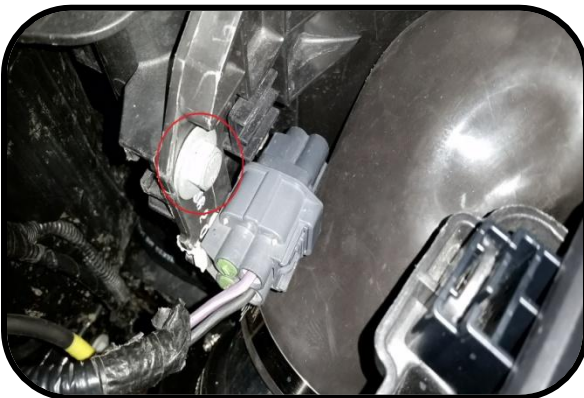

e. Pull the radiator shroud and electric fan up together to remove from the vehicle.

f.

19. Using a 3/8" square drive, remove the factory serpentine belt.

20. Remove the hardware shown below. In order to remove the water pump bolt it may be necessary to first remove the factory belt tensioner. Then tensioner will be reinstalled after the rear plate is installed.

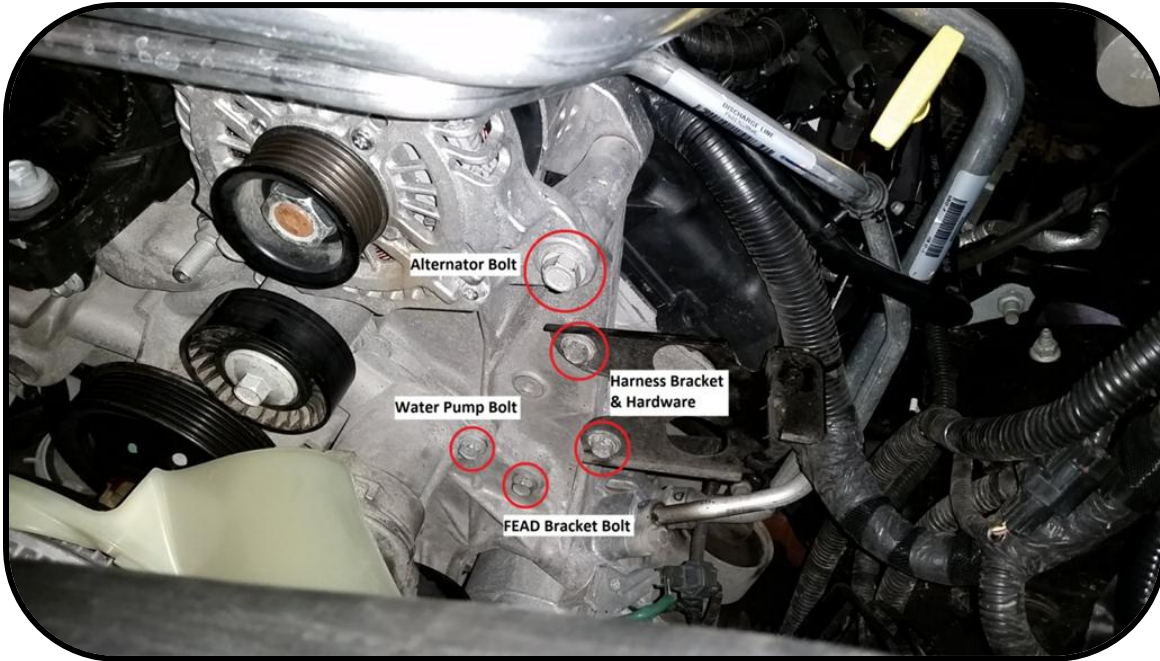

21. Now is a good time to pin the crankshaft balancer. Utilize the provided crank pin kit and instructions.

Assembly

1. To begin the installation we will first install the SC rear plate onto the engine. The SC rear plate uses the five M8 standoffs. Referring to the Figure below:
 - a. (3x) M8x53MM standoffs utilize the M8x85MM bolts. (BLUE)
 - b. (1x) M8x38MM standoff utilizes the M8x130MM bolt. (ORANGE)
 - c. (1x) M8x31MM standoff utilizes the M8x80MM bolt. (GREEN)

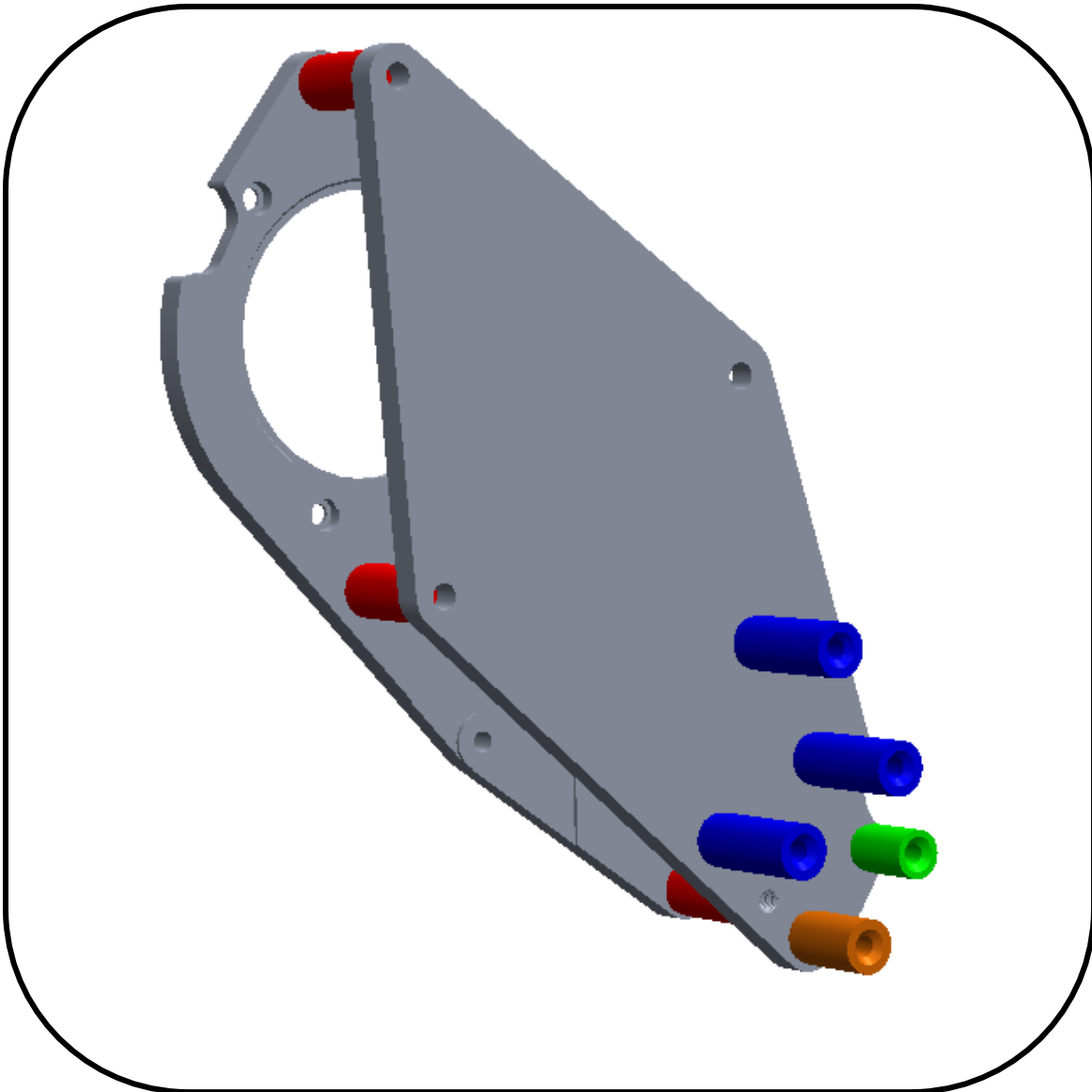

2. Remove the factory belt tensioner. Install the bolts through the front of the rear plate in the proper locations as shown below. Then install the standoffs on the back of the rear plate on the proper length bolts, see pictures. Install the assembled plate as shown and torque the bolts the the specifications listed below. The cutout on the plate will face the tensioner. Reinstall the factory belt tensioner.

Torque Specifications:

M8 Bolts to: 22 lb-ft.

M10 Bolts to: 35 lb-ft.

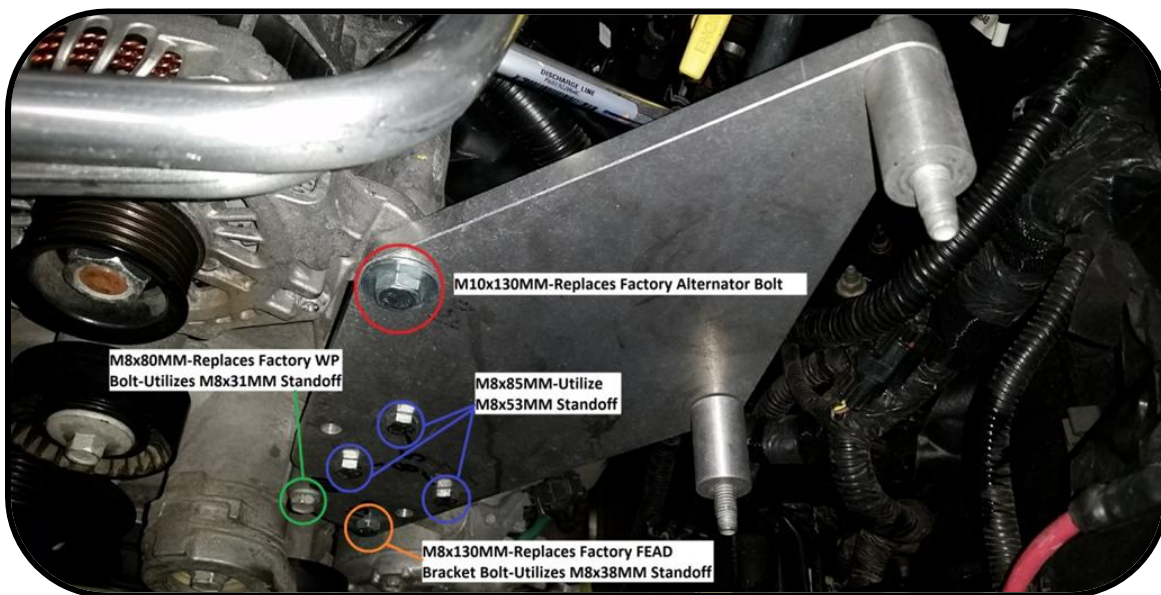

3. With the rear plate installed and torqued, install the assembled front plate with the supercharger and idler pulleys installed. The front plate uses the four M10x40MM standoffs (RED shown below). Utilize the four M10x70MM bolts to fasten the front plate to the rear plate.

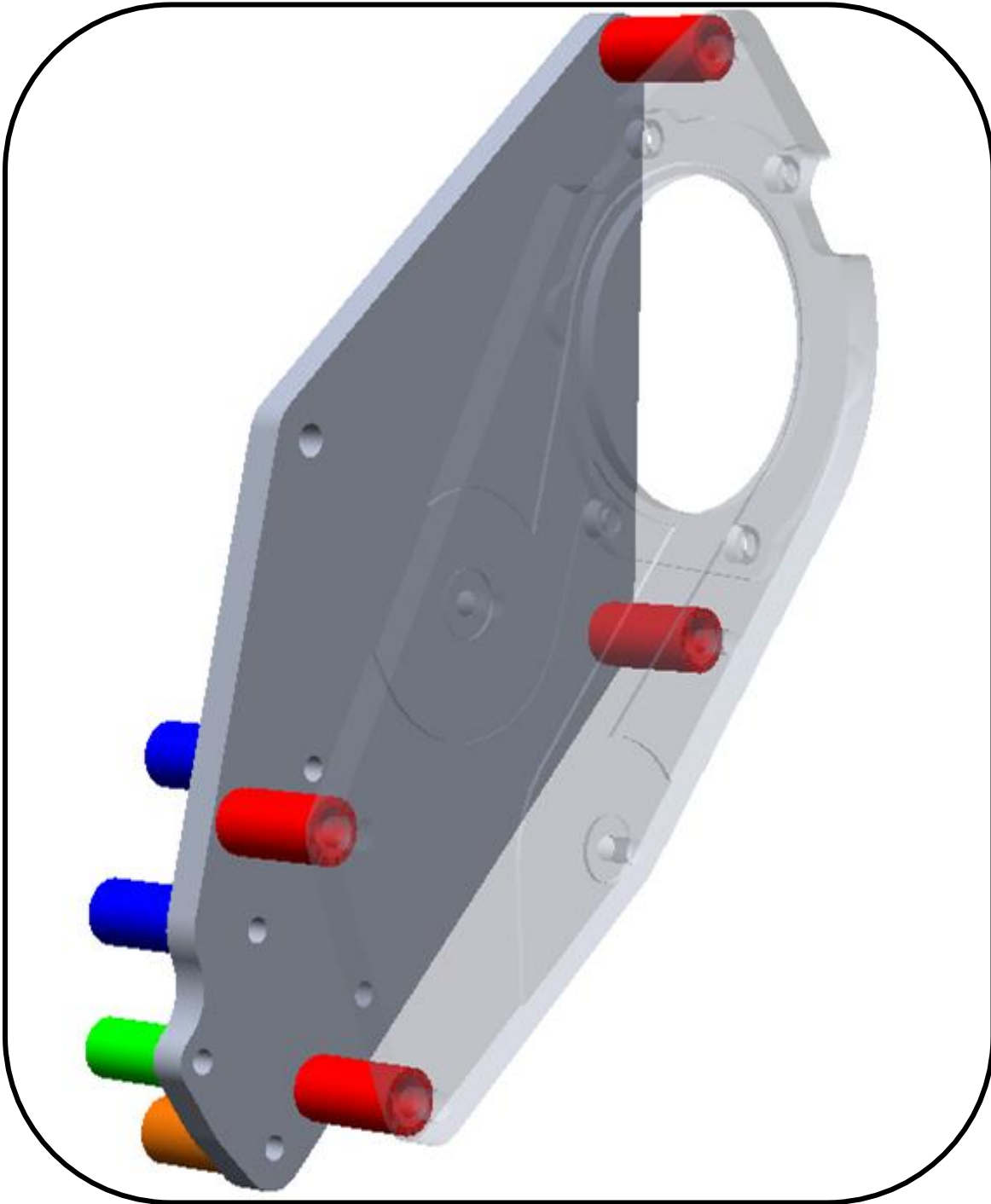

4. Two of the M10x70MM bolts are installed through the rear plate and thread into the front plate. The other two are installed through the front plate and thread into the rear plate (see below).

Torque the M10 hardware to 35 lb-ft. Then the lower two mounting bolts, shown below, will need to be removed in order to install the serpentine belt.

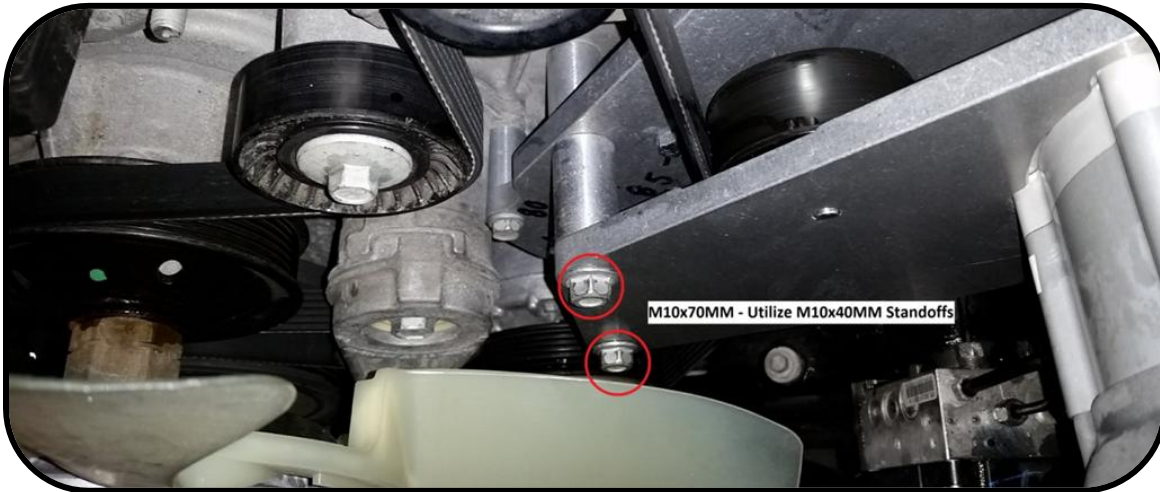

5. When installing the supercharger to the front plate make sure the the flat side of the supercharger head unit is facing the flat relief cut on the plate. The socket head bolts securing the supercharger to the front plate should only be torqued to 11lb-ft.
6. With the lower two standoffs and bolts removed, install the serpentine belt based on the new belt routing diagram shown below.

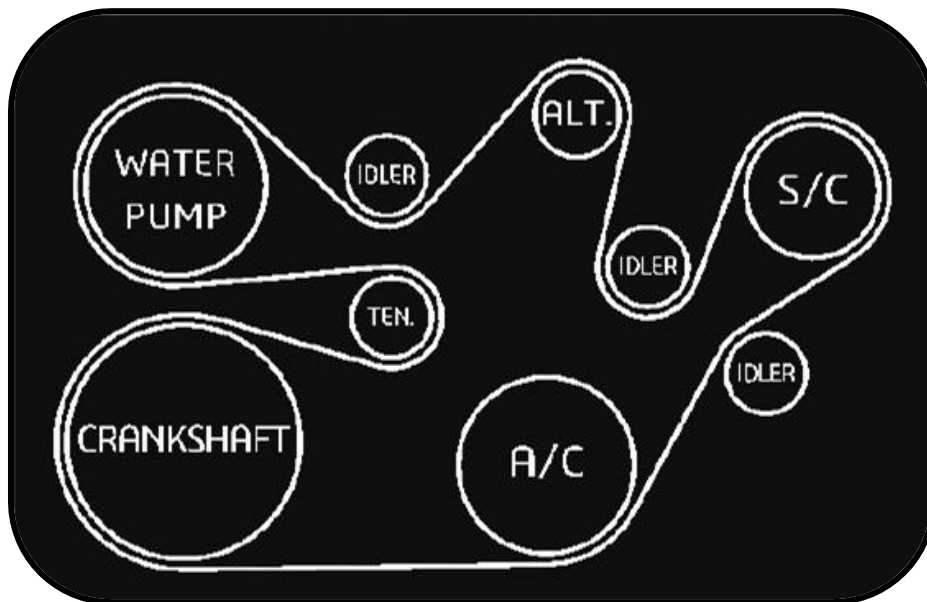

7. With the serpentine belt installed the two lower standoffs and bolts can be reinstalled and retorqued.

8. Moving to the front of the vehicle, the oil cooler will be installed next. Find the driver and passenger side oil cooler brackets and install them onto the oil cooler as shown. The oil cooler is mounted behind the front cross member, using factory threaded holes to secure the oil cooler brackets to the cross member with M6x20MM flanged bolts. The brackets are secured to the oil cooler using M6x16MM flanged bolts and flanged M6 nylock nuts. See below. Note the direction of the barbed fittings coming off of the oil cooler.

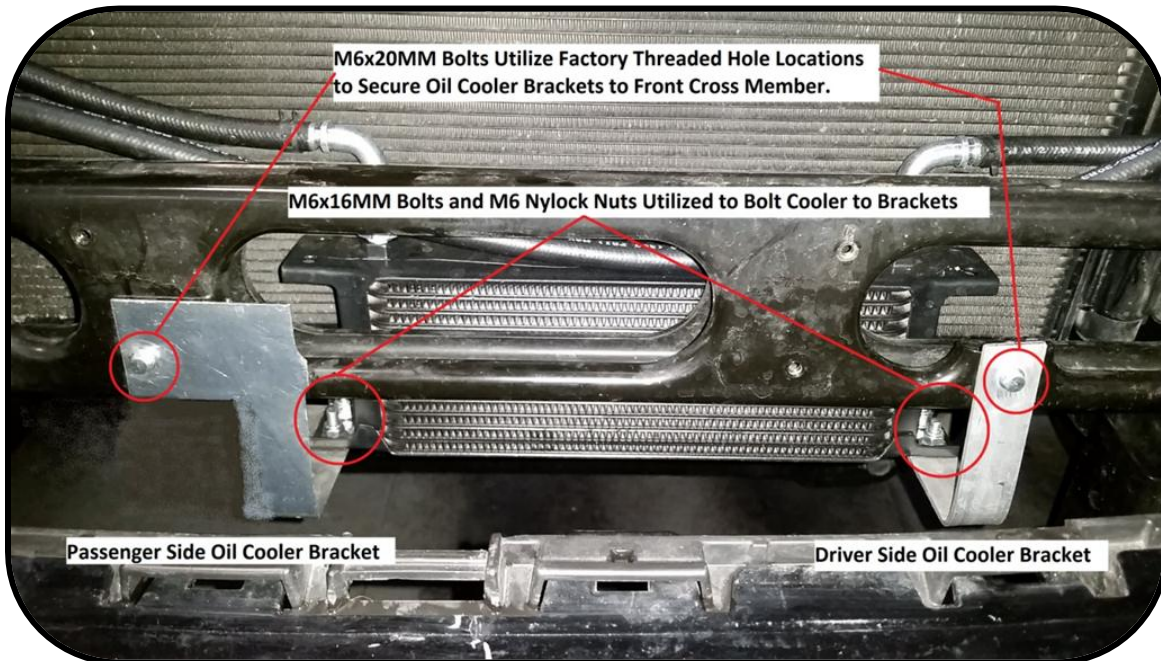

9. The SC oil reservoir will be installed on the passenger side of the radiator support, near the lower radiator hose using factory threaded holes, two 3" loop clamps, and two M6x20MM flanged bolts.

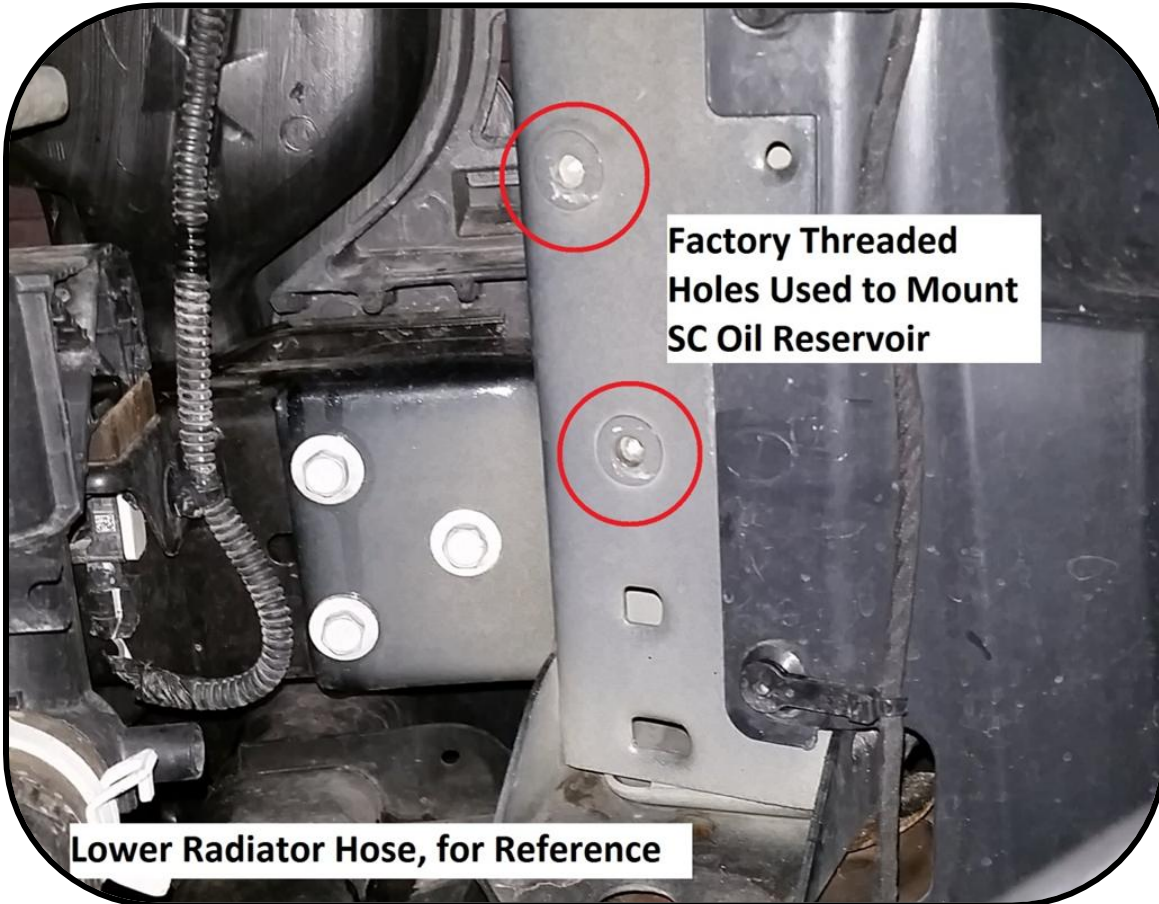

10. Connect the previously installed reservoir, cooler, and supercharger with the provided filter, precut hoses, and hose clamps based on the SC oil system diagram below. Use the provided cable ties to secure the hoses to prevent chaffing or rubbing. Note Figures below for suggested routing.

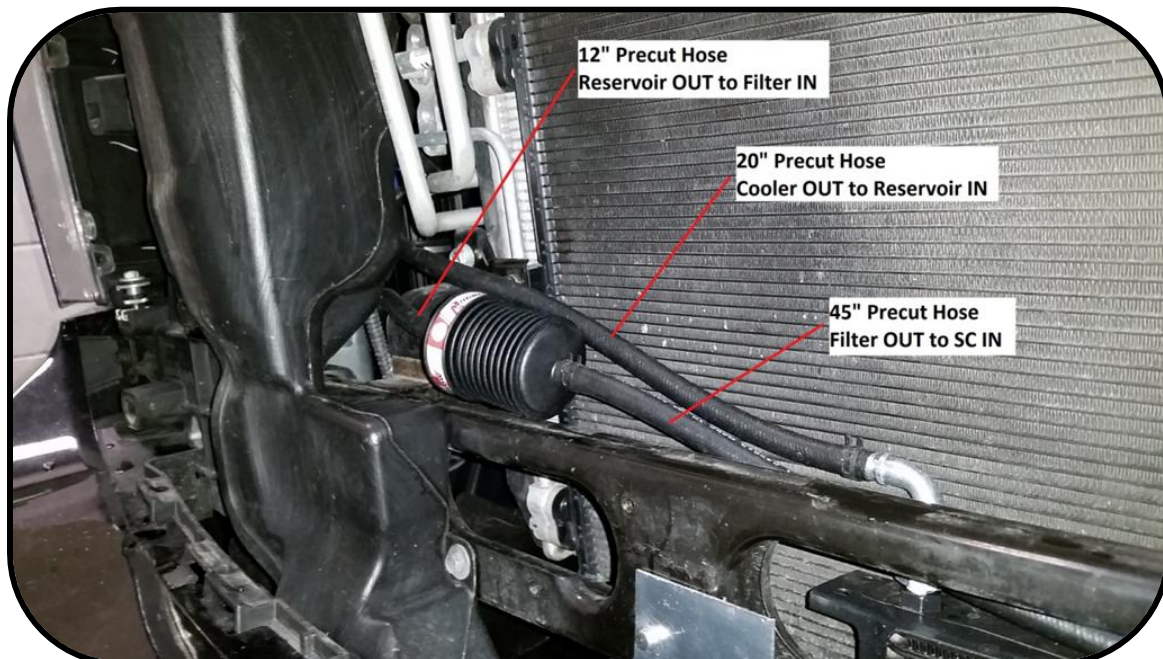
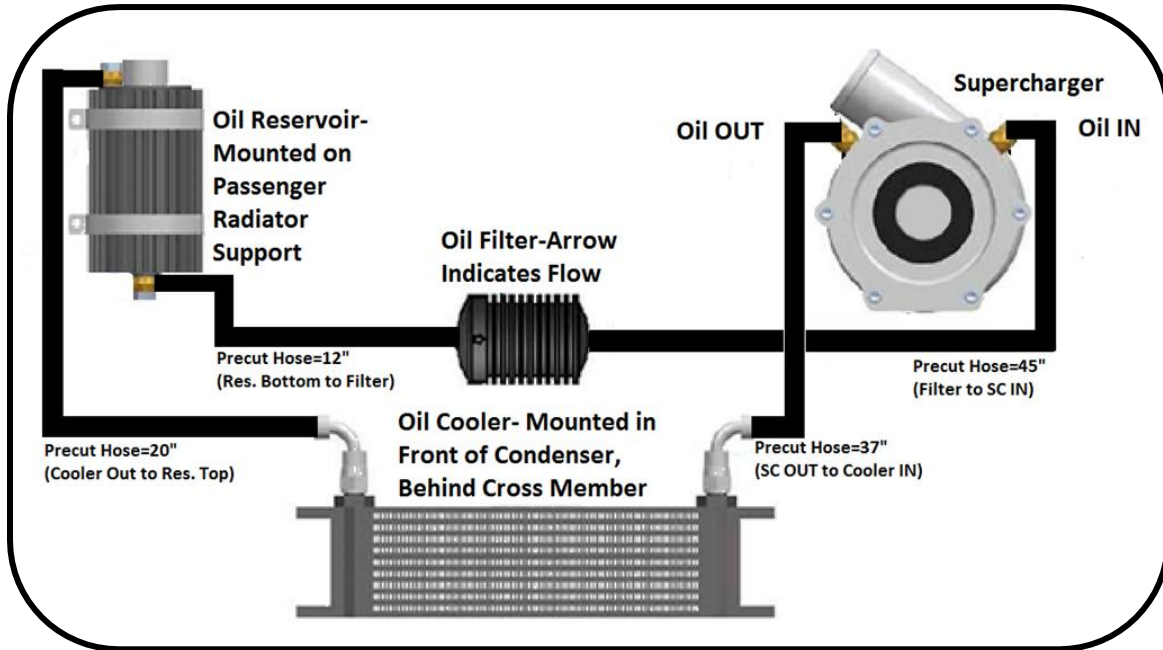

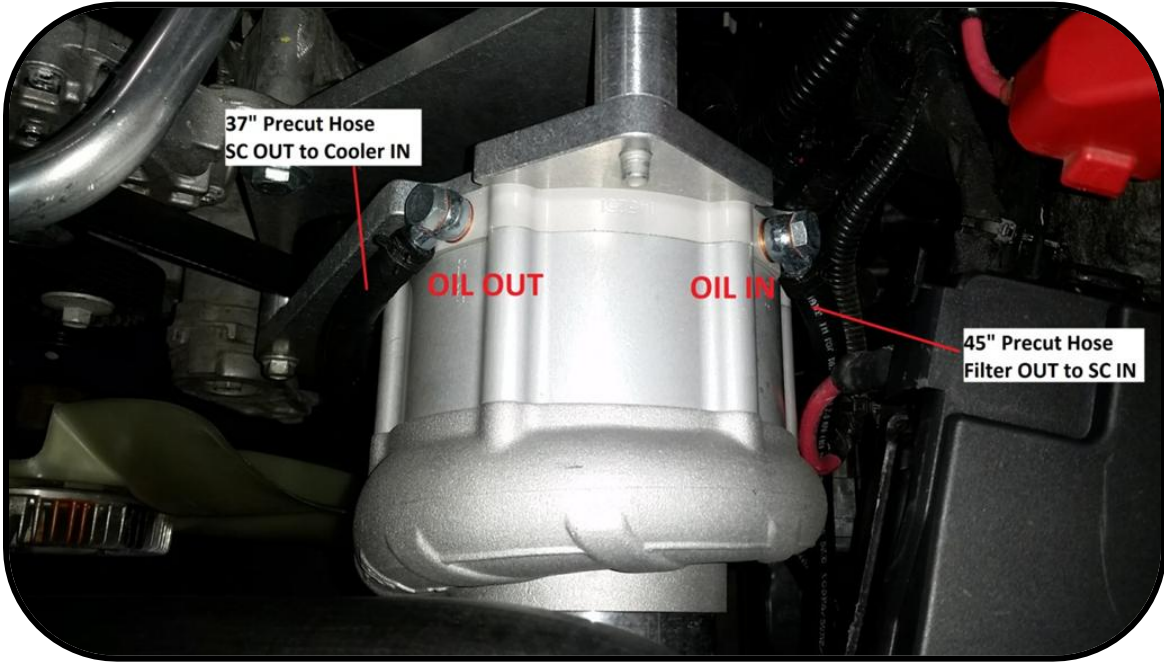
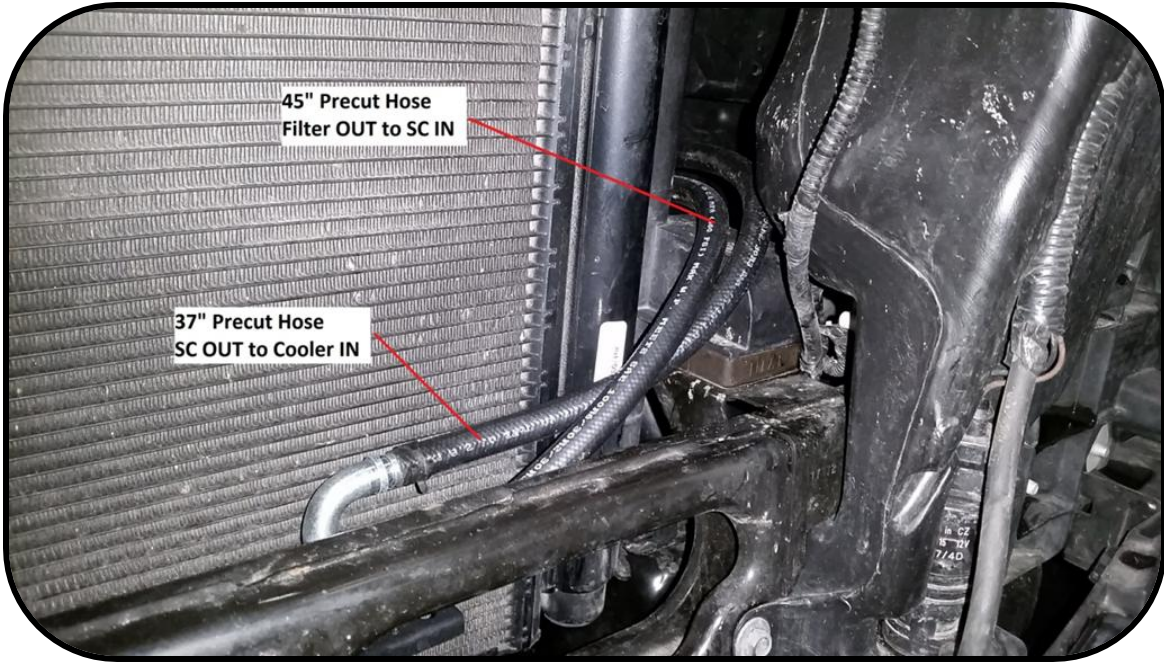

11. With the oil system completed, the intercooler will be installed next. Start with the lower intercooler bracket, which is bolted to the front cross member using the two M6x16MM flanged bolts.



12. Rest the intercooler on the cross member and loosely bolt the lower intercooler bracket to the tab on the bottom of the intercooler as shown, leave this loose for now to allow for adjustment.



13. Install the top left intercooler bracket, use a M8x20MM flanged bolt and M8 nylock to secure the bracket to the intercooler, then use a M8x30MM flanged bolt and the factory threaded hole (originally used to mount the shutters) to secure the bracket to the radiator support. Leave the hardware snug for now to allow room for adjustment.

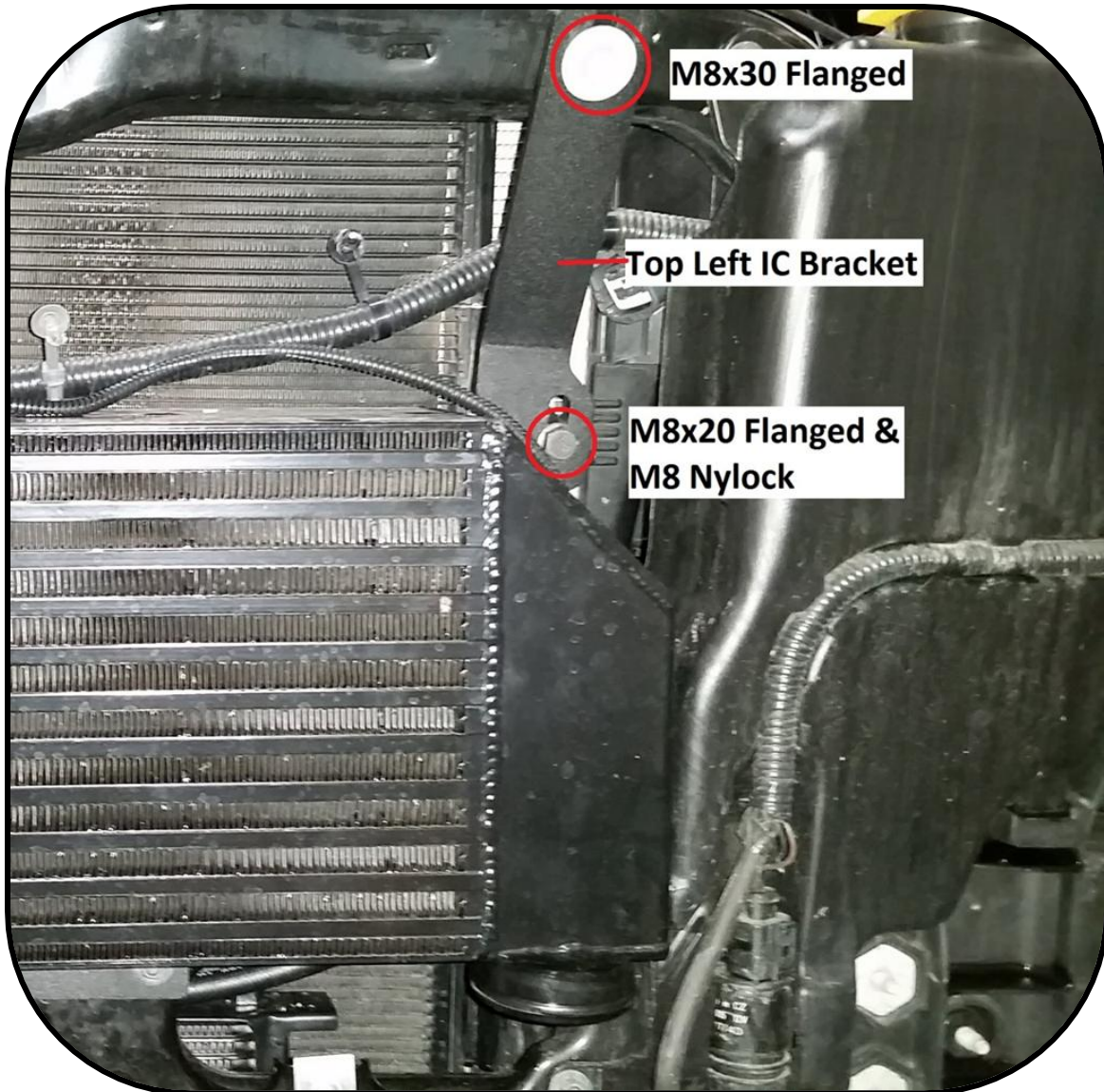

14. Install the top right intercooler bracket, again use the M8x20MM flanged bolt and M8 nylock to secure the bracket to the intercooler. In order to secure the bracket to the body; a 1/4" hole will have to be drilled near the hood latch and an M8 self tapping bolt will be used to fasten it. Install the bracket on the intercooler and snug the bolt, use the bracket as a guide to locate the hole and drill. Secure the bracket with the M8 self tapping bolt. With this complete go back and tighten up the rest of the intercooler mounting hardware.

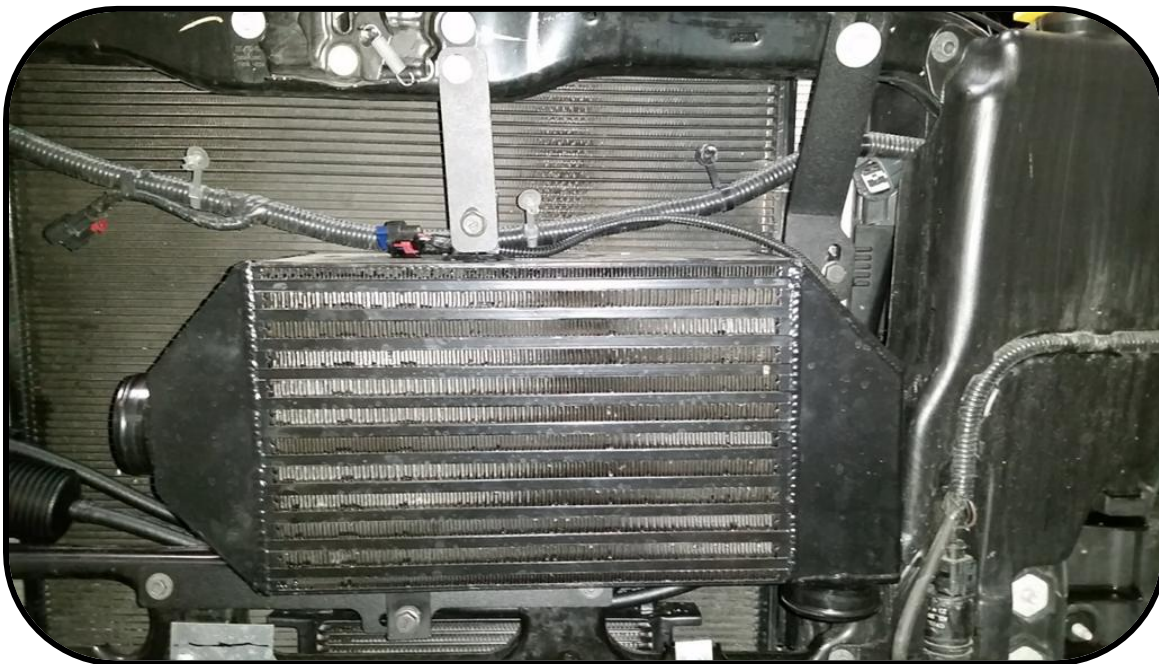
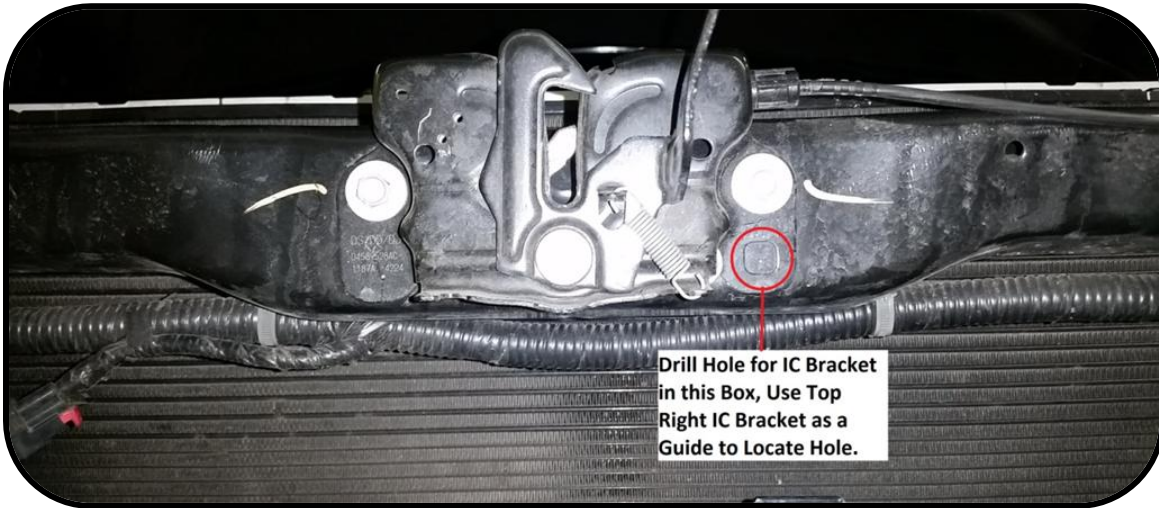

15. With the intercooler installed we can finally connect the system. Starting with the supercharger outlet tube, use the two SAE40 hose clamps to secure the tube between the supercharger and intercooler, as shown.

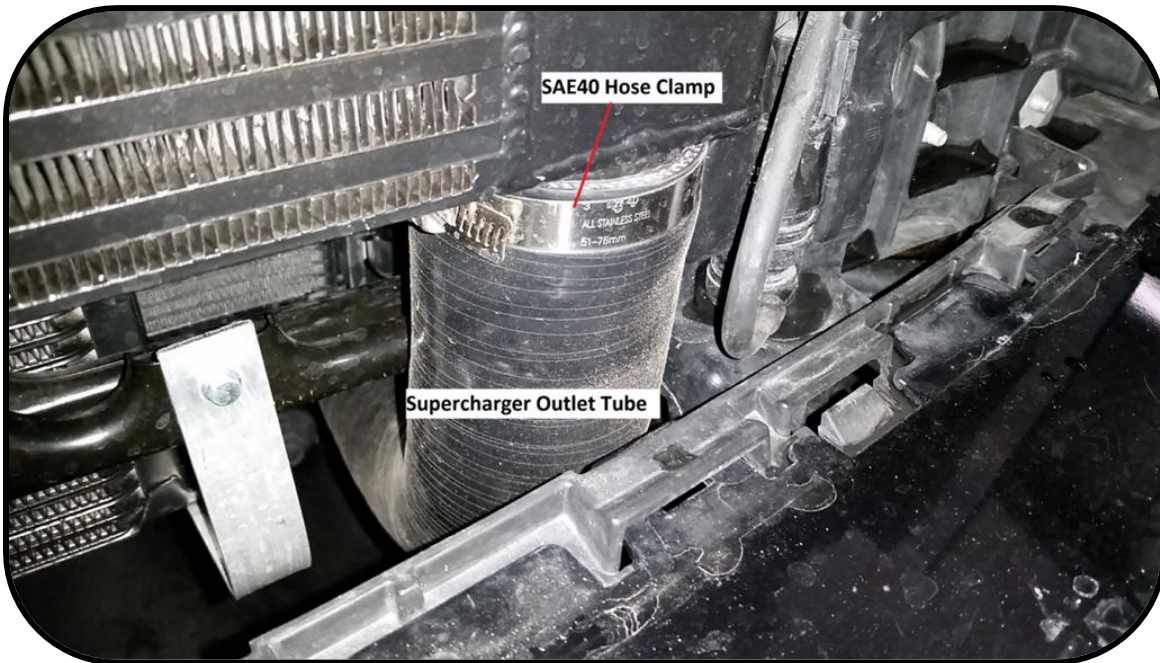
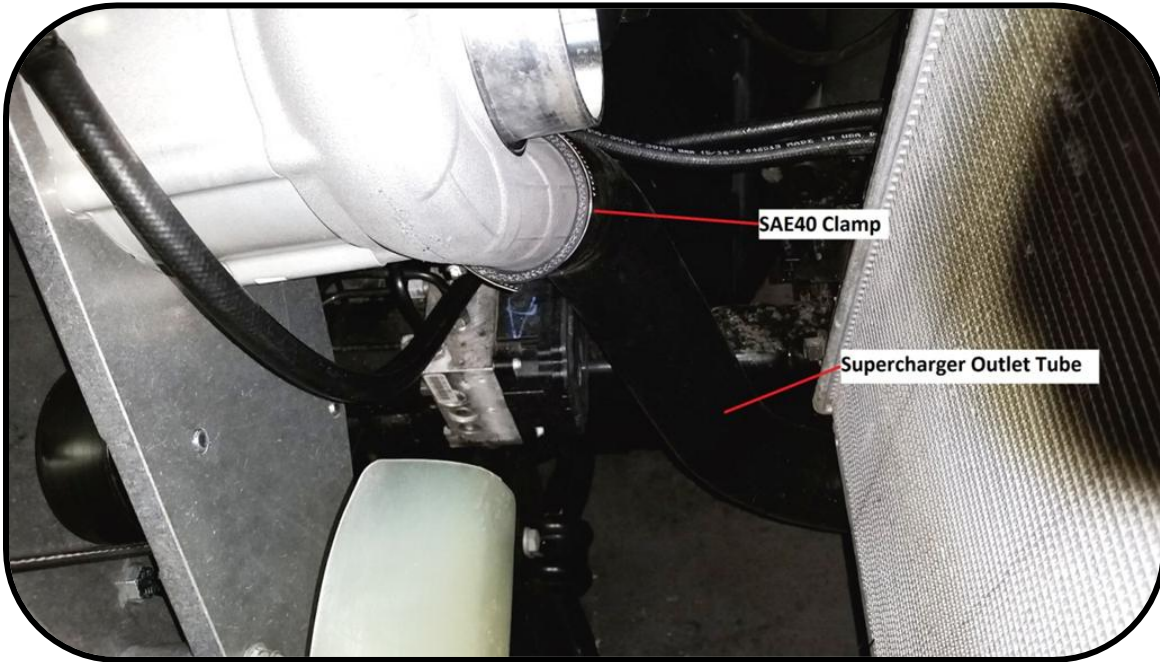

16. Install the BOV onto the intercooler outlet hardtube using the supplied o-ring and v-band clamp. The orientation of the BOV is not critical and the orientation of the barbed fitting can be adjusted later if need be.

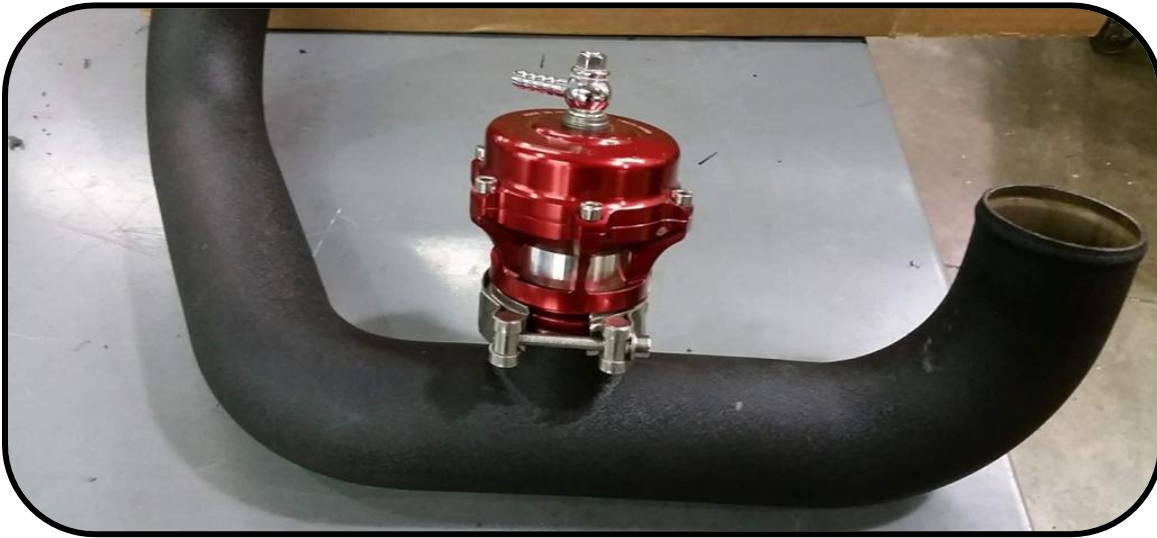

17. Next install the intercooler outlet hardtube and throttle body inlet soft tube. Starting with the hardtube, use the provided sleeve and two SAE40 hose clamps to secure the hardtube to the intercooler as shown.



18. Install the throttle body inlet tube between the open end of the intercooler outlet hardtube and the throttle body. Use the provided SAE40 hose clamp between the intercooler outlet hardtube and throttle body inlet tube. **NOTE: If your RAM is equipped with a factory heater valve the bracket will need to be bent out of the way to clear the tube.**

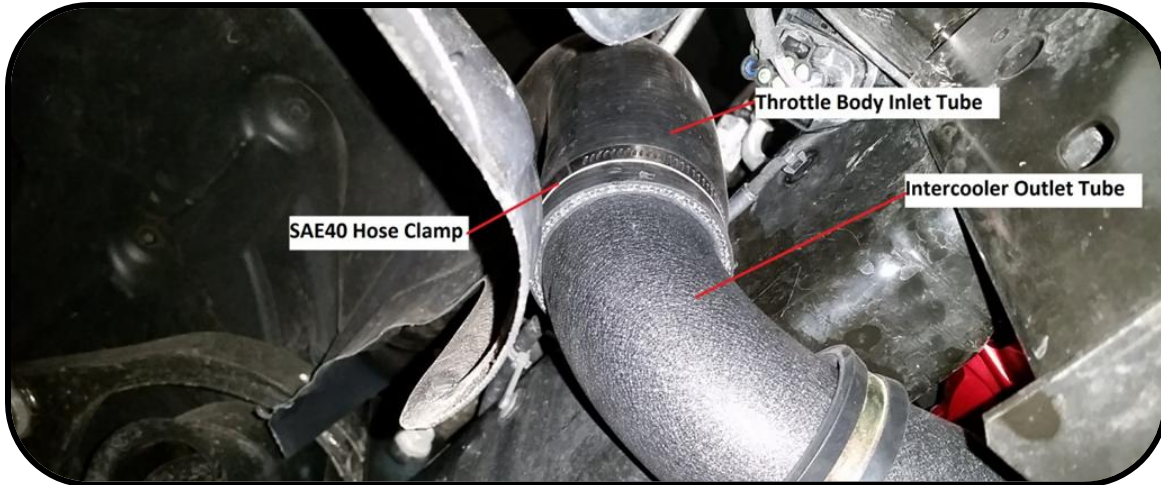

19. Install the provided loop clamp for the intercooler outlet tube underneath the frame rail as shown. Use the clamp as a guide and drill a 1/4" hole in the bottom of the frame. Use the provided M8 self tapping bolt to secure the hardtube to the passenger side frame rail.

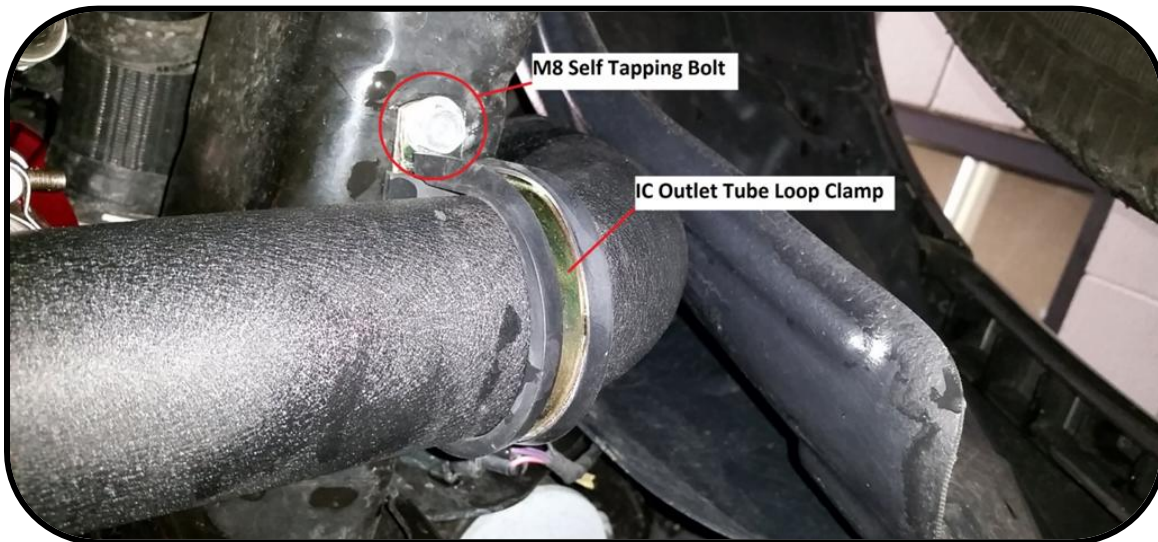

20. For now leave the throttle body end of the throttle body inlet tube loose, as it will need to be moved later.

21. Using the provided $\frac{1}{4}$ "X $\frac{3}{8}$ "X $\frac{3}{8}$ " vacuum "T", $\frac{1}{4}$ " vacuum line, and hose clamps, plumb the vacuum supply to the BOV through the Brake Booster vacuum supply hose, as shown. Install the provided "pill" into the $\frac{1}{4}$ " vacuum supply hose for the BOV. Route the $\frac{1}{4}$ " hose to the fitting on the BOV and secure it with a hose clamp. Make sure the vacuum hose is not rubbing or chaffing and secure it with the provided cable ties if need be.

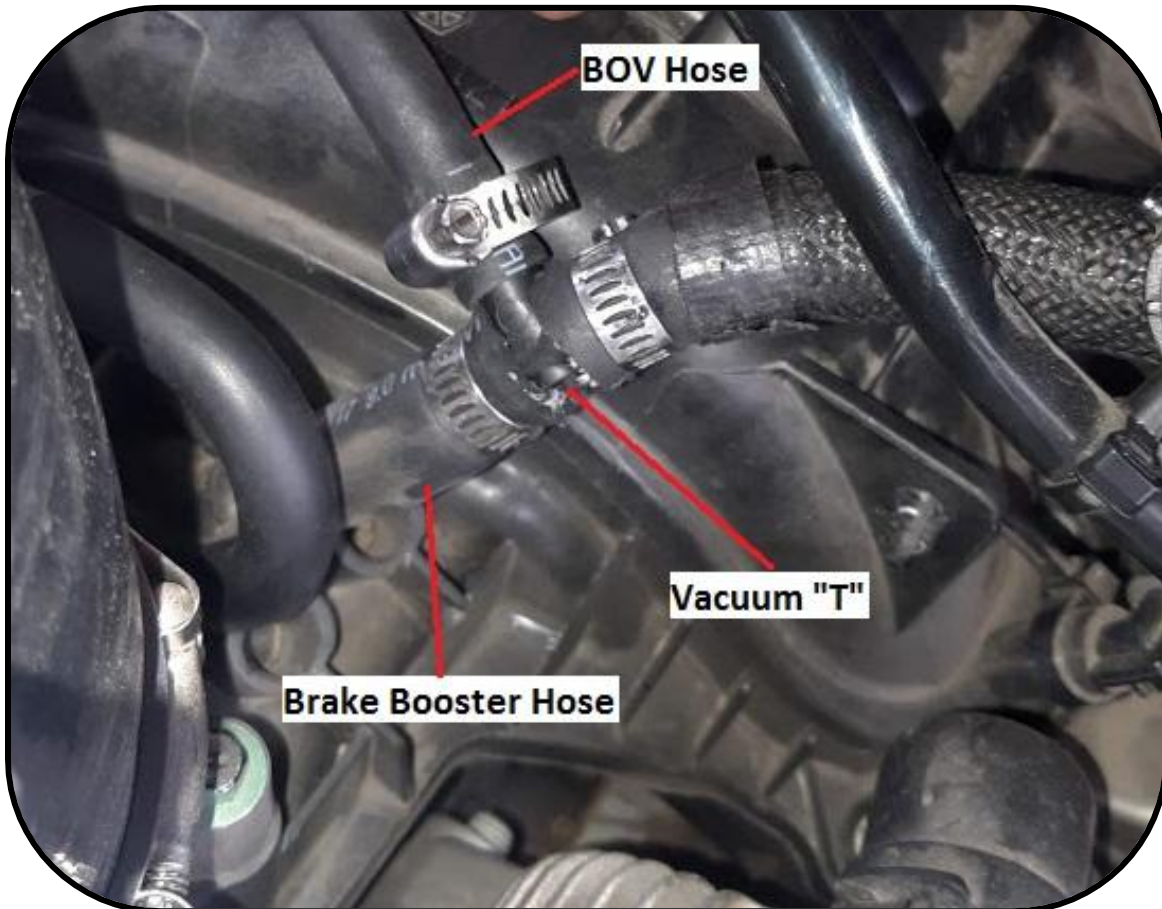

22. At this point the radiator fan shroud and electric cooling fan can be reinstalled by reversing the procedure described earlier in this manual. Once this is done the lower radiator fan shroud can be reinstalled.

23. Next install the supercharger inlet boot onto the supercharger using the SAE60 hose clamp to secure, only snug the clamp for now to leave room for adjustment.

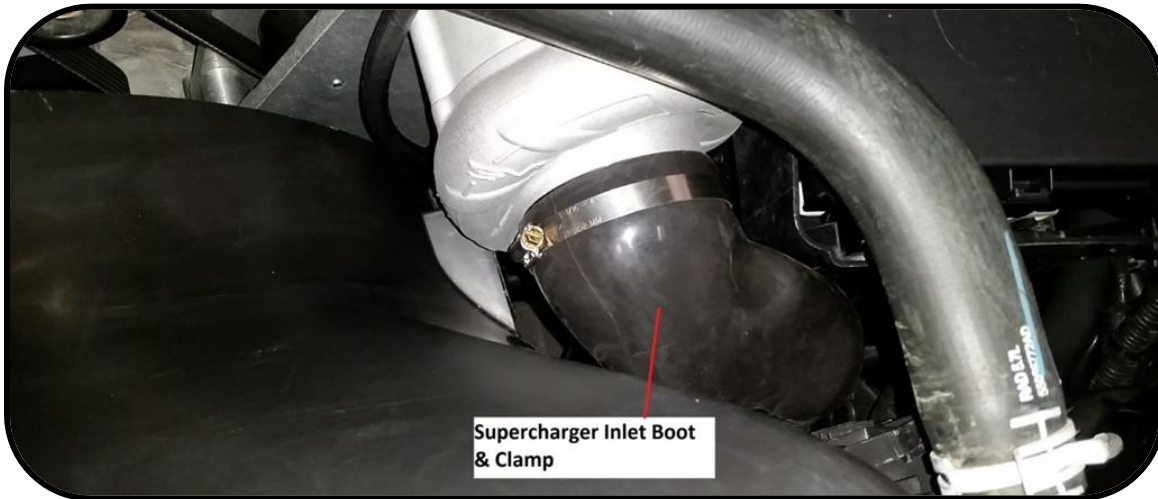

24. Install the provided 3.5" OD straight tube section on the open end of the SC inlet boot using the other SAE60 hose clamp. Working from the bottom install the provided cone filter on the open end of the straight tube section.

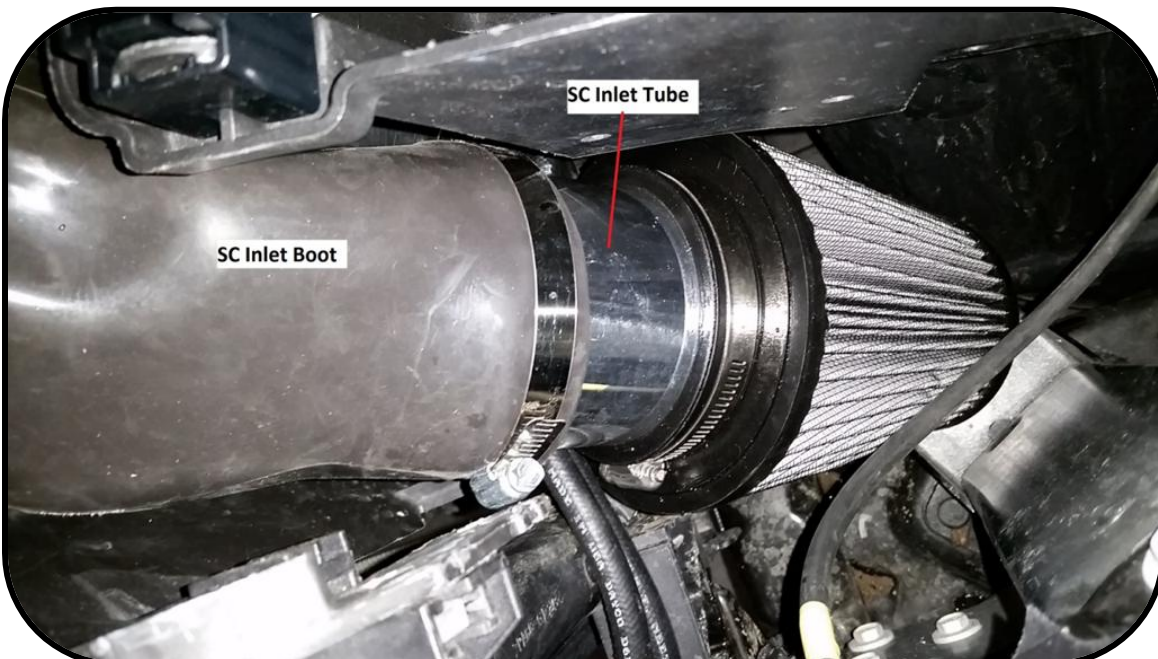

25. Preassemble the new MUA hose using the provided precut 19/32" ID by 46" long PCV Hose, 3/4" to 5/8" adapter, 5/8" OD 90° barb fitting, and the factory 90° soft boot as shown below.

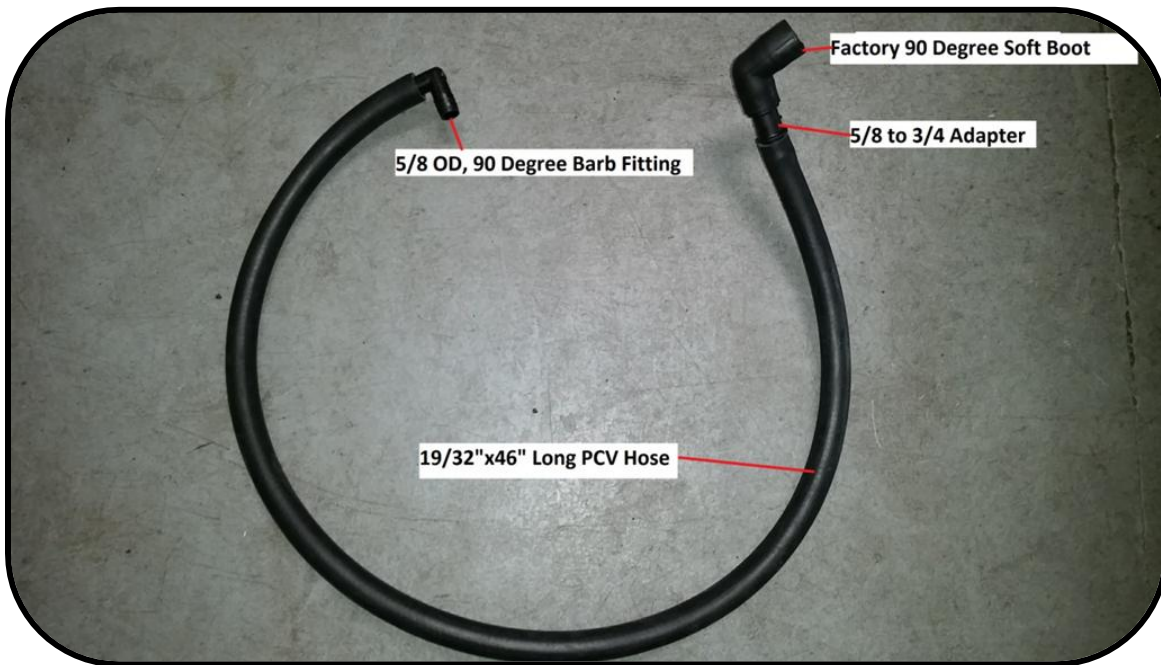

26. The open end of the barb fitting will be installed in the hole in the front of the air filter as shown, the factory soft boot will be installed in the factory location near the oil fill. You will need to drill a 5/8" hole in the front of the air filter.



27. Now go back and install the throttle body inlet tube onto the throttle body using the provided 3.5" t-bolt clamp. The clamp will be installed with the two provided t-bolt brackets as shown. First remove the two throttle body screws shown. Then install the brackets onto the clamp, install the clamp and brackets onto the tube, and install the tube onto the throttle body. With the clamp loose, line up the brackets to the throttle body holes and reinstall the throttle body screws through the brackets. Tighten these screws all the way and then back off ½ of a turn. Tighten the t-bolt clamp and then final tighten the throttle body screws.

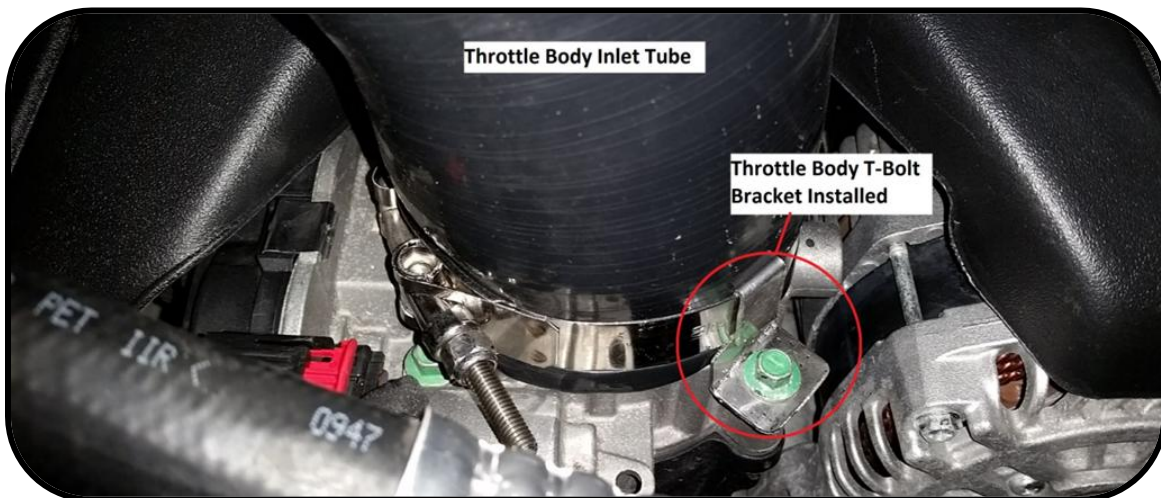

28. It is a good idea to retorque the intake manifold now, as the o-rings have most likely settled slightly, see Step 12 of the Disassembly.

29. At this point you can fold the throttle body inlet tube forward in order to install the engine cover.

30. With the engine cover installed, install the factory air intake temperature sensor into the new throttle body inlet tube and secure it with the provided hose clamp.

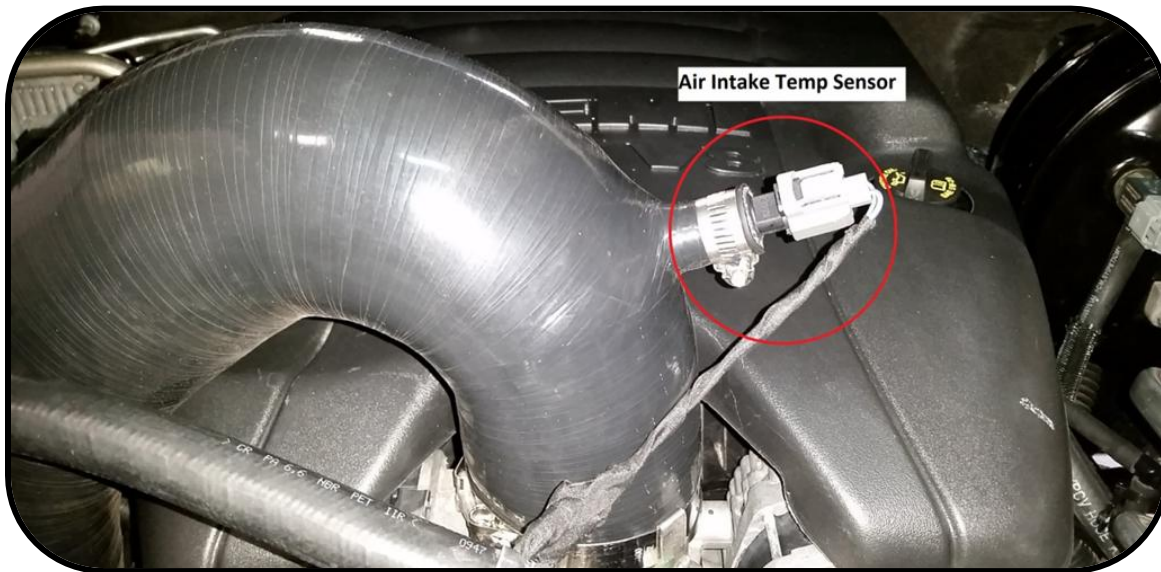

31. At this point the supercharger system is almost complete, it is a good idea to double check your work and ensure that all of the clamps and hardware have been tightened and that none of the plumbing or rubber hoses will be chaffed or damaged during operation.

32. Install the tuned ECU from HSI.

33. Reconnect the negative battery cable.

34. At this point the vehicle should run but the SC traction oil system **needs to first be primed.**

Follow the **Initial Startup Oil Bleed Process** on the last page of this manual.

35. After bleeding the traction fluid system run the vehicle and check for any leaks, repair as needed before reinstalling the grill.

36. The back of the grill will need to be slightly clearanced on the driver side in order to clear the intercooler. Refer to the figures below for approximate cut lines.

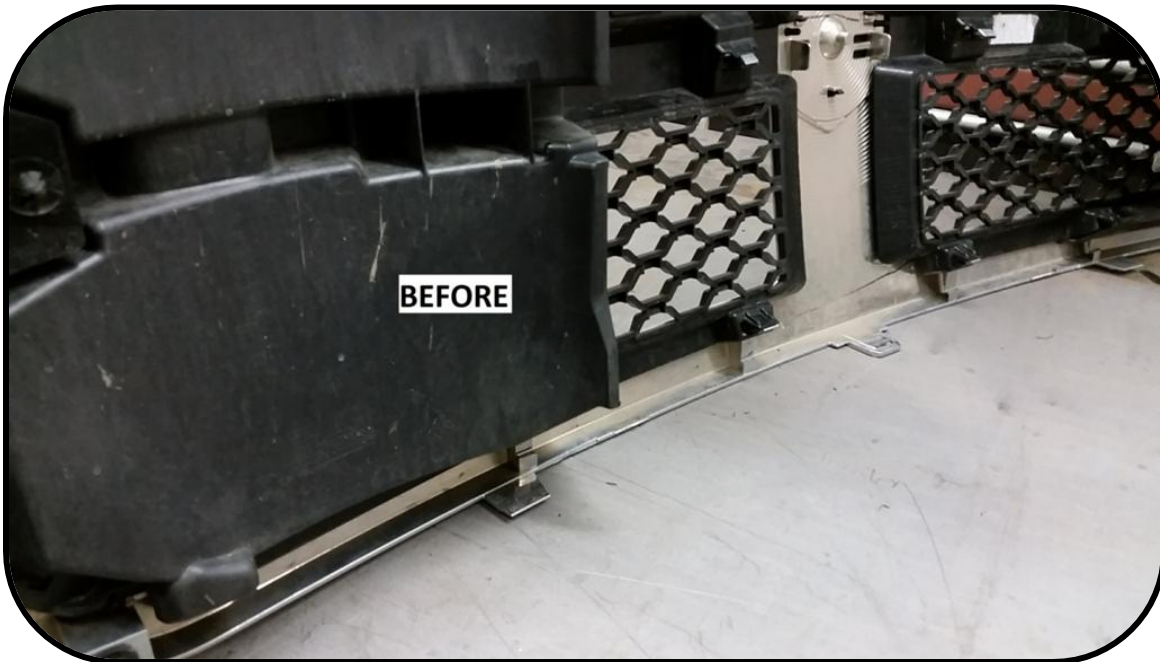



37. Reinstall the grill.

38. Reinstall the sight shield.

Initial start up after Oil Change/Oil Fill

To ensure proper traction fluid circulation and adequate lubrication, it is important to prime the oil system before the engine is started for the first time and after the oil change/oil fill.

1. Carefully fill the oil canister with traction fluid without exceeding the maximum mark on the dip stick. The oil level is measured with the thread of the dip stick cap fully engaged
2. The banjo bolt at the oil line attached to the supercharger inlet marked "oil inlet" should be loosened a couple of turns allowing air to escape the system
3. **Carefully** apply pressurized air to the oil filler hole at the top of the canister. **Do not pressurize the system to more than 10psi.** Use a rag or a sponge as a seal between the air gun and the canister
4. When oil appears at the "oil inlet" with no signs of air, tighten the banjo bolt and the system is primed
5. Carefully top up the oil canister to the maximum mark on the dip stick
6. Turn on the engine and rev it to 2000-3000 rpm and make sure the oil starts flowing by visual inspection, looking into the oil canister. Do not rev the engine more than specified as this can cause damage to the supercharger. **MAKE SURE THE RESERVOIR DOES NOT EMPTY DURING THIS STEP OR AIR WILL BE INTRODUCED INTO THE SYSTEM AND DAMAGE WILL OCCUR. IF IT DOES START TO EMPTY POUR MORE FLUID IN. UTILIZE AT LEAST ¾ OF THE SUPPLIED BOTTLE OF FLUID TO PRIME AND FILL THE SYSTEM.**
7. Let the engine idle for 5 minutes while checking the oil system for leaks.
8. The supercharger traction oil and filter **MUST** be changed every 2 years or 24,000 miles, whichever occurs first or you **WILL VOID YOUR WARRANTY** and failure is likely to occur.
9. Check the oil level periodically using the correct procedure

<i>Hamburgers Superchargers Part Number</i>	<i>Description</i>	<i>QTY Required</i>
906822102	Supercharger Oil (1L)	1
210326512	Magnetic Oil Filter	1

The installation is now complete.